

Operation and adjustment instructions

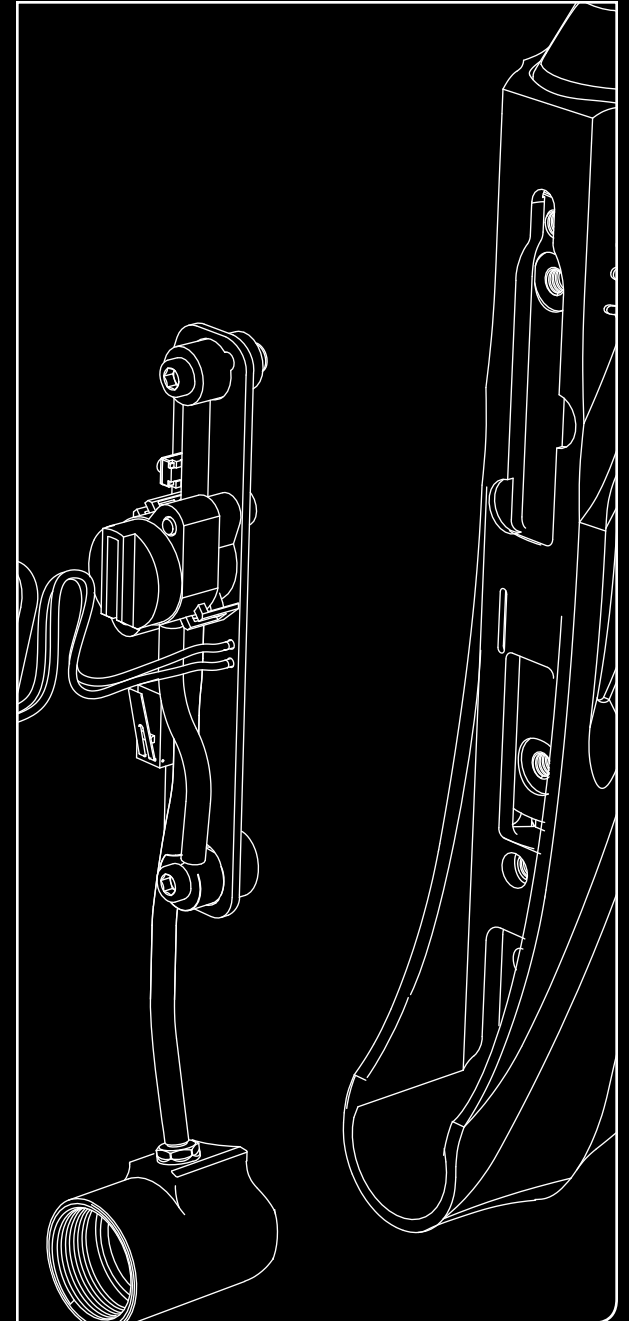
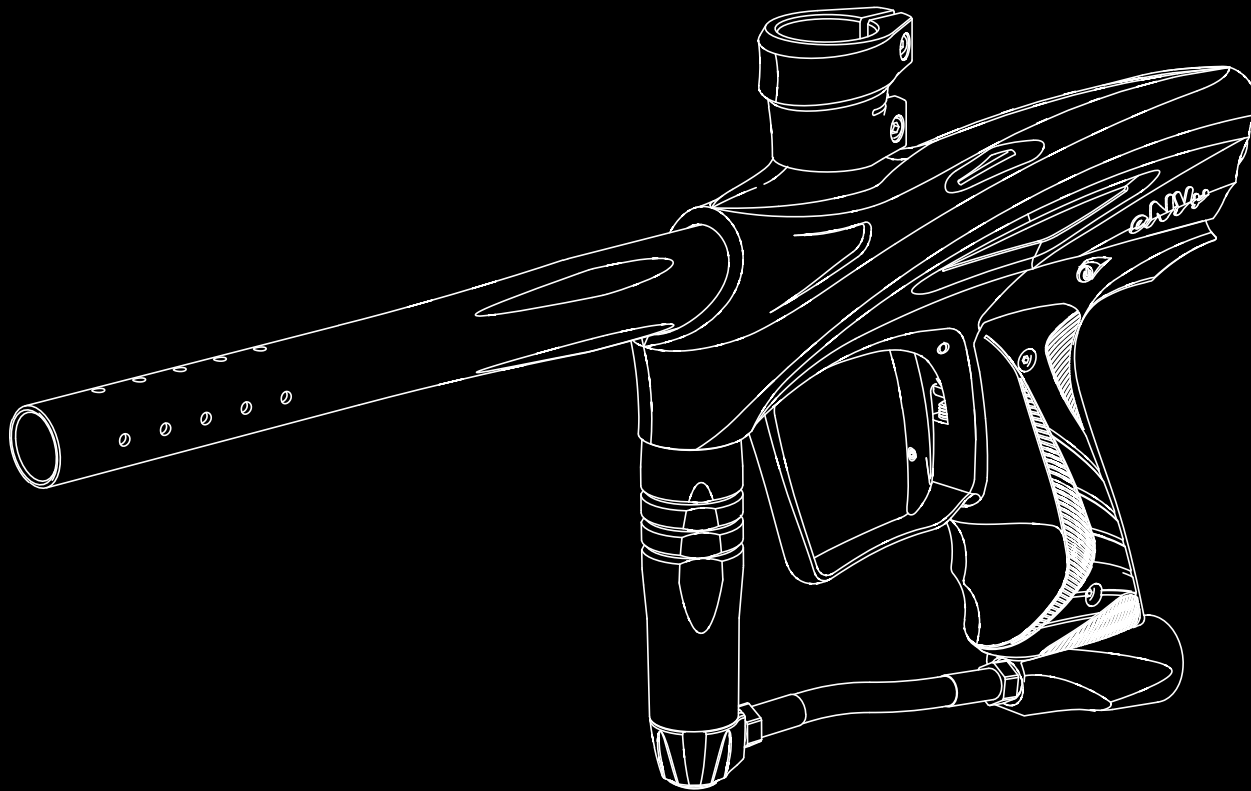

# QUICK START

## 01 BARREL

Unpack the Envy™ and its barrel. Screw the barrel into the front of the marker, hand tight. Take care not to strip the barrel threads or over-tighten.

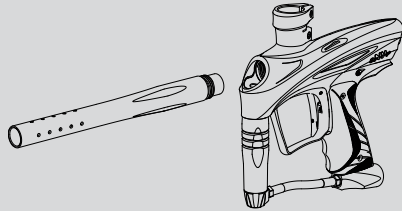

## 02 BARREL BLOCKER

Put the supplied barrel blocker over the end of the barrel, securing its cord as far back on the Envy™ body as possible, and cinching it tight.

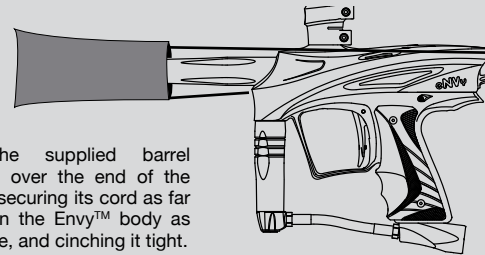

## 03 FILL TANK

Have your compressed air (HPA) or CO<sub>2</sub> tank filled by a person who is properly trained to do so. If using an HPA system with an on/off valve, make sure it is in the OFF position. If using a CO<sub>2</sub> tank or screw-in style preset HPA system, fill it while it is removed from the marker.

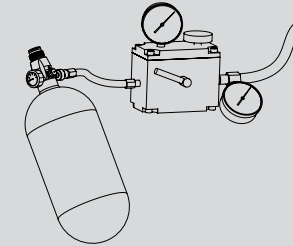

## 04 LOADER

Fit a paintball loader into the feedback of the Envy™. Use a 7/64-inch allen wrench to lock the loader in place. Powered force-feed loaders are recommended, as the Envy™ has little recoil, and can easily outpace an unpowered or agitating loader.

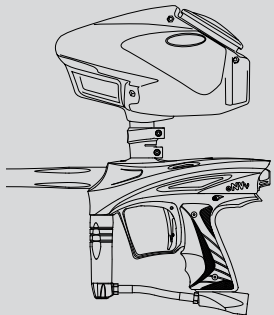

## 05 TURN ON GAS

Gently gas up the Envy™ by slowly turning on the air system or screwing the CO<sub>2</sub> or screw-in style HPA system into the bottom-line ASA.

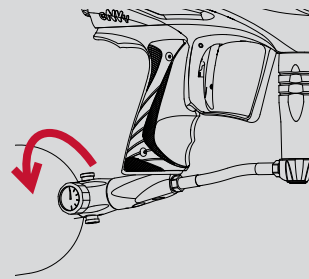

**///////⚠WARNING**  
A gentle rise in pressure is important, as a sudden blast may reduce the service life of the Envy®'s internal components.

## 06 TURN ON THE ENVY™

Turn on the Envy™ by pressing the power button momentarily.

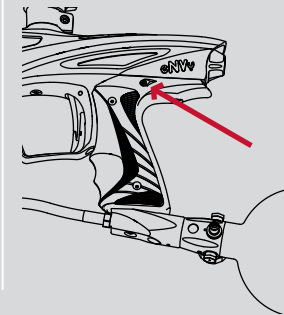

**///////⚠WARNING**  
Although the power button serves as the Envy™'s safety switch to prevent accidental firing, it should never be relied upon in place of a barrel blocker and proper eye protection.

## 07 ADJUST VELOCITY

Fill the loader with paintballs. If it is a powered loader, turn it on. While wearing ASTM compliant paintball goggles, in an area where all bystanders are protected, remove the barrel blocker and fire over a chronograph to measure the velocity. Using a 5/32-inch allen wrench on the adjuster in the bottom of the vertical regulator, turn clockwise to increase the velocity/pressure, and counter-clockwise to decrease. Take three or four shots after every adjustment to allow the gas pressure inside the Envy™ to stabilize. Adjust until the marker is firing consistently within the limits for the field where you are playing (for safety reasons, never adjust the Envy™ to fire at greater than 300 feet per second). Depending on what modes of fire are allowed at the field where you are playing (semi-automatic, rebound, etc.) you may need to adjust the Envy™'s firing mode. See the Electronic Adjustment section for more information.

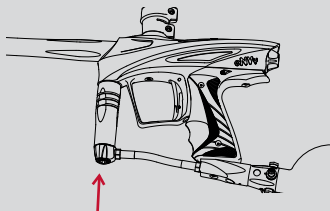

# TABLE OF CONTENTS

<b>Quick Start</b>	<b>00</b>
Table of Contents and Safety Warnings	01
Getting Familiar	02
Barrel Blocker / Hopper	03
Gasses	04
Battery	06
Paint	07
Trigger Adjustment	08
Firing Modes / Dwell	09
Unloading / De-Gassing	10
Field Stripping	11
Advanced Maintenance	12
Vertical Regulator	14
Troubleshooting / Warranty	16
Parts Diagrams	19

## ///////⚠️WARNING

- THE ENVY™ IS NOT A TOY.
- MISUSE OF THE ENVY™ MAY RESULT IN SERIOUS INJURY OR DEATH.
- EYE PROTECTION DESIGNED FOR PAINTBALL USE MUST BE WORN BY THE USER AND ANY PERSON WITHIN RANGE OF THE ENVY™.
- GOG PAINTBALL® RECOMMENDS THAT THE ENVY™ ONLY BE SOLD TO PERSONS 18 AND OLDER.
- THOROUGHLY READ THE ENVY™ OPERATION AND INSTRUCTION MANUAL BEFORE OPERATING.
- TREAT EVERY PAINTBALL MARKER AS IF IT WERE LOADED.
- NEVER LOOK DOWN THE BARREL OF A PAINTBALL MARKER.
- KEEP YOUR FINGER OFF THE TRIGGER UNTIL READY TO SHOOT. NEVER POINT THE ENVY™ AT ANYTHING YOU DON'T INTEND TO SHOOT.
- KEEP THE ENVY™ ON SAFE (POWER OFF) UNTIL READY TO SHOOT (SEE QUICK START).
- KEEP THE BARREL BLOCKING DEVICE ON THE ENVY™'S MUZZLE WHEN NOT SHOOTING (SEE BARREL BLOCKER SECTION).
- ALWAYS REMOVE PAINTBALLS AND DE-GAS THE ENVY™ BEFORE DISASSEMBLY (SEE DEGASSING SECTION).
- STORE AND TRANSPORT THE ENVY™ UNLOADED AND DEGASSED IN A SECURE PLACE.
- FOLLOW ALL MANUFACTURER'S WARNINGS AND INSTRUCTIONS FOR PROPELLANT SOURCE HANDLING, STORAGE AND FILLING.
- DO NOT SHOOT FRAGILE OBJECTS SUCH AS WINDOWS.
- ALWAYS MEASURE THE VELOCITY OF PAINTBALLS FIRED BY THE ENVY™ BEFORE USE, AND NEVER ADJUST TO FIRE ABOVE 300FPS (91.44M/S).

# GETTING FAMILIAR

PLEASE READ CAREFULLY

## → STATISTICS

WEIGHT:	1 lb. 11oz.
OPERATING PRESSURE:	160 psi
POWER SOURCE:	9-volt Alkaline Battery
PROPELLANT:	CO <sub>2</sub> or Nitrogen/Compressed air
RATE OF FIRE:	11 bps
OPERATION:	Low pressure electropneumatic
MODES OF FIRE:	Semi-Automatic, Billy-Ball™, PSP and Select Fire
ANTI CHOP SYSTEM:	Low-Force bolt
BARREL THREAD:	GOG®
LUBRICANT:	For proper and consistent operation, the Envy™ should only be lubricated with GR33SE™ lubricating grease.

## MAINTENANCE

The Envy™ has been designed with simplicity in mind so that you can concentrate on your game instead of your marker. It has only one major moving part in its valve system, with a minimal number of seals. This DOES NOT mean that you should neglect your Envy™. If you take care of it off the field, your Envy™ will take care of you on the field. For best performance, clean and grease your Envy™ frequently. Many players disassemble and clean their Envy™ after every day of use. While this may seem a bit extreme, being vigilant in the upkeep of your Envy™ will extend its useful life considerably, and catch any problems when there is time to correct them before the next game. Playing in the rain will not damage your Envy™. In fact, the Envy™ has been tested and proven to function underwater. However, long-term exposure to moisture can cause rust damage to some of the Envy™'s screws, so if your Envy™ should become waterlogged, remove the barrel, stock and rubber grips and allow it to dry out, then follow the disassembly instructions for full cleaning. Clean out mud and paint with a damp cloth and alcohol. Lubricate the Envy™ ONLY with GR33SE™ pneumatic grease. Use fresh, high quality paintballs for best performance.

## → REQUIRED ITEMS FOR USE

- 5/32-inch Allen Wrench (included) - Velocity Adjustment
- Chronograph (provided for use at commercial paintball field) - Velocity Adjustment
- Barrel Blocker (included)
- CO<sub>2</sub> or HPA tank (purchase separately)
- ASTM Compliant Paintball Goggles with Mask (purchase separately)
- 68 Caliber Paintballs
- Paintball Hopper/Loader (purchase separately)
- 9-Volt Alkaline Battery

## → REQUIRED ITEMS FOR MAINTENANCE

- 0.050-inch Allen Wrench (included) Trigger Adjustment
- 5/64-inch Allen Wrench (included) - Battery Change
- 7/64-inch Allen Wrench (included) - Clamping Feedneck
- 1/8-inch Allen Wrench (included) - Stock/Backplate, Trigger Adjustment, ASA, Grip, Breech and Circuit Board Screws
- 5/32-inch Allen Wrench (included) - Velocity Adjustment
- 5/16-inch Allen Wrench (included) - Bolt Sleeve
- Snap-Ring Pliers (purchase separately) - Regulator Disassembly (Advanced Maintenance)
- GR33SE™ (purchase separately) - Paintball Marker Lubricant

# BARREL BLOCKER/HOPPER

## BARREL BLOCKER

The Barrel Blocking Device is a critical piece of paintball safety equipment - nearly as important as paintball goggles. The Barrel Blocker serves to protect against accidental discharge of a paintball by catching it before it can cause harm. A Barrel Blocker is included with the Envy™ and must be used every time it is handled in an area where people or property are not properly protected by paintball goggles or paintball field netting. To use the Barrel Blocker simply slip it over the end of the barrel and stretch its cord back over the back of the Envy™ or the rearmost part over which it can be securely looped. Use the strap's adjuster to cinch the strap tight, so that the Barrel Blocker can provide protection against accidental discharge of a paintball.

## //////⚠WARNING

The Barrel Blocker should only be removed when the Envy™ is on a "live" paintball field and all persons involved are wearing proper paintball protection.

## HOPPER

The Envy™ is a high performance tournament grade paintball marker. Its low-force bolt will often prevent paintballs from being chopped if the hopper is not able to load paintballs as fast as the Envy™ is being fired. If you want to realize the Envy™'s maximum firepower potential, especially if it is upgraded with a circuit board that utilizes an anti-chop eye for higher rates of fire, you will need to use a high performance loader. High performance loaders, especially those which provide force-feeding, will yield the best results with the Envy™.

The Envy™ is equipped with a clamping feedneck that allows it to adapt to the small size differences in hopper neck sizes, yet lock or release quickly. Using a 7/64-inch allen wrench, loosen the clamping feedneck before installing a hopper. If the hopper is a tight fit, a flat bladed screwdriver may be used to further spread the gap in the feedneck clamp, provided the clamp screw has been loosened enough.

The Envy™ may also be configured so that the hopper is located to the right, left, or directly above the center of the marker. See the Advanced Maintenance Section of this manual for instructions to change or reposition the feedneck.

PLEASE READ CAREFULLY

FIG. 1 → BARREL BLOCKER IN USE

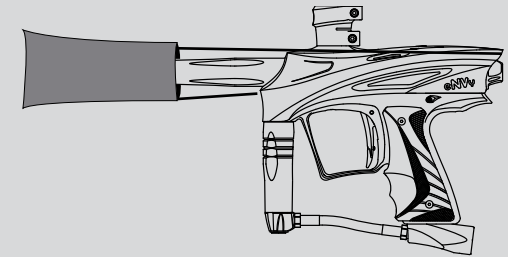
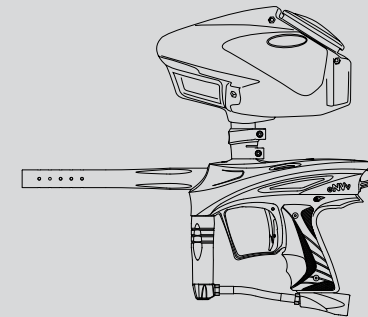

FIG. 2 → USE HIGH PERFORMANCE LOADER



# GASES

## GASES

The Envy™ is a low-pressure paintgun. It operates at approximately 160 psi, which means it is capable of functioning well with either high-pressure compressed air or CO<sub>2</sub> as a power source. Proper set up of your gas system will help you obtain the best possible performance from your Envy™.

Whether using compressed air or CO<sub>2</sub> it is important that the Envy™ is not exposed to sudden “pops” of pressure. Always turn-on or screw-in a compressed air system or CO<sub>2</sub> slowly, so that the valve opens slowly, and the gas pressure inside the marker is raised smoothly. Be gentle to the internals of your Envy™ and they will reward you with a long service life.

High Pressure Air systems (HPA) are the preferred power source used in paintball as they are unaffected by temperature fluctuations and do not have the potential for liquid problems. HPA systems consist of a tank and a regulator, and are typically rated to store air or nitrogen at pressures of 3,000 or 4,500 psi. Although pure nitrogen is almost never used in paintball, many players call compressed air “nitro” as air is made up of more than 70% nitrogen, allowing the two gasses to be used interchangeably in paintball equipment.

The Envy™ is configured for use with screw-in style HPA systems. Although HPA systems pre-set to deliver approximately 400 psi (low output) will work with the Envy™, 800 psi (high output) systems are preferred, to reduce the risk of gas starvation under rapid fire.

### //////////⚠WARNING

Never use oil or any petroleum based cleaner or lubricant in a compressed air regulator or tank. Exposure to pressurized air increases oil's flammability and can cause a serious safety hazard. Only use manufacturer recommended lubricants with compressed air systems, and follow the manufacturer's maintenance and operation instructions explicitly.

If you are using your Envy™ with an adjustable output compressed air system, it should be set to deliver about 800 psi. The Envy™'s vertical regulator can accommodate a wide range of input pressures, so exact adjustment of the air system is not critical.

### //////////⚠NOTICE

Due to shipping restrictions, CO<sub>2</sub> and HPA tanks are sold empty. They must be filled before they can be used. Most paintball shops and fields are equipped to fill HPA tanks. Paintball shops, fields, many hardware stores and sporting goods stores will have the equipment and trained personnel to fill paintball CO<sub>2</sub> tanks.

### //////////⚠WARNING

NEVER PUT OIL IN A COMPRESSED AIR REGULATOR OR TANK - ONLY APPLY MANUFACTURER RECOMMENDED LUBRICANTS.

FIG. 3 → HPA TANK BEING FILLED

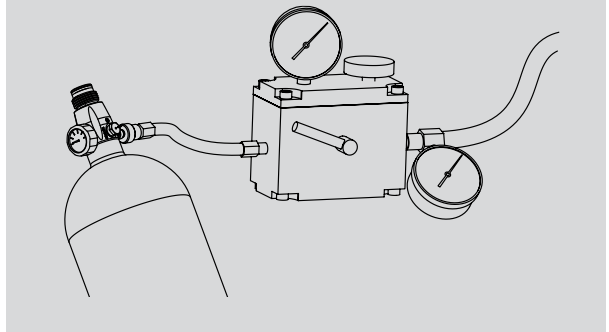

### //////////⚠NOTICE

The Envy™ is factory configured for use with CO<sub>2</sub>. Its dwell setting must be changed to obtain optimum performance with HPA. See the Firing Modes / Dwell section of this manual to learn how.

### //////////⚠NOTICE

Although the Envy™ can be powered by compressed air, typical home, garage or industrial air compressors cannot provide the high pressures required to fill a paintball HPA tank. Paintball HPA systems can be refilled by paintball fields and stores which use higher pressure compressors similar to those used in the SCUBA and firefighting industries.

# GASES

## USING CO<sub>2</sub>

CO<sub>2</sub> is usually not recommended for electronic paintball markers. This is not the case, however with the Envy™. As long as it is set up properly, the Envy™ can function extremely well with CO<sub>2</sub> as a power source. In fact, because of its extremely low operating pressure, the Envy™ has been shown to operate on CO<sub>2</sub> continuously under heavy fire conditions where older design blowback mechanical markers fail. The use of CO<sub>2</sub> will not damage the seals in the Envy™, freeze or cause damage to its circuit board.

The important thing to remember if using CO<sub>2</sub> is that best performance can be achieved when only gaseous CO<sub>2</sub> is fed to the Envy™, and liquid CO<sub>2</sub> remains in the tank.

Although the relief valve integrated into the Envy™'s vertical regulator provides the marker with protection from pressure spikes, those pressure fluctuations can cause poor performance, and temporary blockage of the Envy™'s solenoid valve.

The bottom-line ASA fitting on the Envy™ places the CO<sub>2</sub> tank at an angle. When the marker is held in typical firing positions, gravity will keep the liquid CO<sub>2</sub> away from the tank valve, preventing it from feeding into the marker.

Alternative CO<sub>2</sub> arrangements include placing the CO<sub>2</sub> tank vertically in a pack, and using a paintball CO<sub>2</sub> remote hose to feed CO<sub>2</sub> to the Envy™. This arrangement not only prevents liquid CO<sub>2</sub> from entering the marker, but also makes the marker assembly lighter weight.

Anti-siphon CO<sub>2</sub> tanks contain a J-shaped tube that draws gaseous CO<sub>2</sub> from the top of the tank when it is in a horizontal position. Anti-siphon tubes must be professionally installed, to ensure that critical safety checks are performed during valve installation. If using an anti-siphon tank, the Envy™'s stock bottom-line ASA fitting should be replaced with an ASA that will place the tank completely horizontal. Anti-siphon CO<sub>2</sub> tanks should not be used with remote hoses.

## BOTTOM-LINE ASA

The bottom-line ASA fitting on the Envy™ can be removed by unscrewing the two industry-standard 10-32 mount screws holding it to the grip frame. If replacing the ASA, be sure the model chosen takes into account the type of gas system being used (horizontal for anti-siphon CO<sub>2</sub> tanks, angled for standard tanks).

PLEASE READ CAREFULLY

FIG. 4 → ANGLED CO<sub>2</sub> [CUTAWAY VIEW]

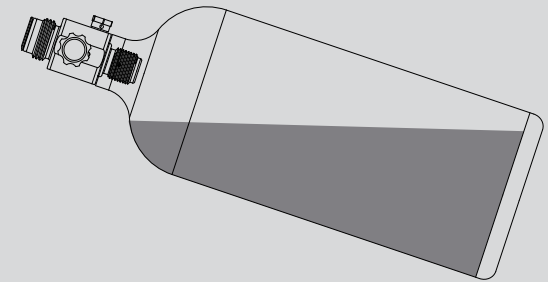
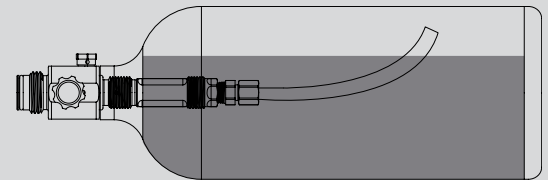

FIG. 5 → CO<sub>2</sub> WITH ANTI-SIPHON [CUTAWAY VIEW]



## IMPORTANT

CO<sub>2</sub> may also be configured with a remote hose with-out Anti-Siphon. [Not Shown]

# BATTERY

## WARNING

OVER TIME BATTERIES MAY LEAK. ALWAYS REMOVE THE BATTERY FROM THE ENVY™ WHEN STORING FOR MORE THAN A MONTH.

### BATTERY

The Envy™ is powered by a standard 9-volt alkaline battery. Lower cost “heavy duty” batteries will not consistently deliver the amperage needed to operate the Envy™. Erratic performance, especially drops in velocity or skipped shots during rapid fire can result from a battery that is not delivering full power.

The Envy™ is also compatible with 9-volt rechargeable batteries. Because specifications of batteries vary widely from brand to brand, use of any rechargeable battery will require testing to determine if it can power the Envy™ reliably. Some NiCD “9v” rechargeable batteries actually operate at 7.2 volts. These types of batteries will not work well with the Envy™.

Any time the Envy™ exhibits erratic performance, drops velocity or skips shots while rapid firing, does not shoot or does not turn on, the first step in troubleshooting should always be to replace the battery with a brand-new, name-brand alkaline battery.

To replace the Envy™ battery, use a 5/64-inch allen wrench to remove the two screws from the left side of the rubber grip, then open the grip. Remove the old battery, taking care not to bend, kink or strain its wires. Unsnap the battery from its connector by pulling on the connector, not the wires. Snap in a fresh battery, then place that in the grip frame, tucking the wires into place, before closing and re-securing the grip.

FIG. 6 → ALKALINE BATTERY

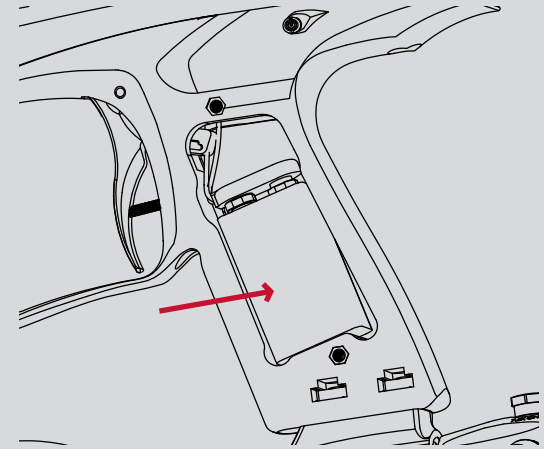



# PAINT/VELOCITY

## PAINT

Even the best quality paintballs will vary in size from one batch to the next and as weather conditions change. While your Envy™ will work well even with a poor paint to barrel fit, optimal performance will be achieved with a proper fit.

The ideal fit between the paintball and the barrel is when the ball is inserted in the bore (the end that screws into the Envy™) and does not slip or roll through to the muzzle (the business end) on its own. The ball should sit in place, even when the barrel is pointed straight down. If the paintball can roll out on its own, the fit is too loose. The ball should be able to be expelled from the barrel by blowing it out, like a blowgun, using a minimal amount of breath. If the ball is difficult to blow through, the fit is too tight, which can lead to ball breakage.

## VELOCITY

The velocity, or speed at which a paintball is fired from the Envy™, must be measured and adjusted to below the paintball field's velocity limit immediately before each day of play (for player safety). If CO<sub>2</sub> is used, velocity should be checked and adjusted multiple times during the day. In an area where it is safe to fire paintballs, while wearing ASTM compliant eye and face protection for paintball, fire three or four shots over a chronograph to measure the velocity at which the paint is being fired.

If velocity adjustment is necessary, Use a 5/32-inch allen wrench on the adjuster in the bottom of the vertical regulator, turn clockwise to increase the velocity/pressure, and counter-clockwise to decrease. Take three or four shots after every adjustment to allow the gas pressure inside the Envy™ to stabilize. Adjust until the marker is firing consistently within the limits for the field where you are playing. For safety reasons, never adjust the Envy™ to fire at greater than 300 feet per second (91.44 meters per second).

## WARNING

NEVER ADJUST THE Envy™ TO FIRE ABOVE 300 FEET PER SECOND, AS SERIOUS INJURY MAY RESULT.

FIG. 7 → VELOCITY ADJUSTMENT

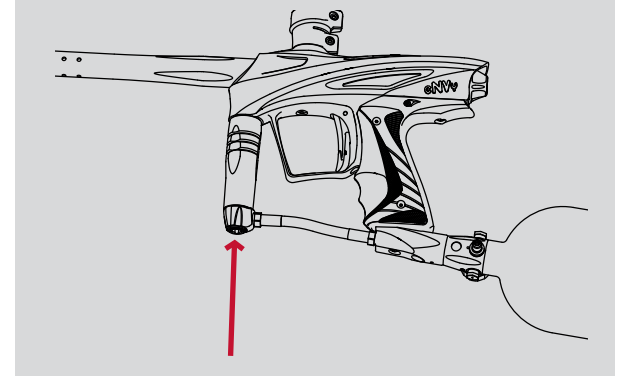

# TRIGGER ADJUSTMENT

The length of the Envy™ trigger pull is fully adjustable. A setscrew in the lower half of the trigger limits how far back the trigger can be pulled. Turning the screw clockwise with a 0.05-inch allen wrench will shorten the trigger pull. Turning counter-clockwise will increase it. When setting the rear trigger limit, it is important that the trigger pull is not set so short that the trigger does not activate the microswitch on the Envy™'s circuit board, or the marker will not be able to fire. Similarly, the rear limit screw must butt up against its stop when the trigger is pulled. If the rear trigger limit is under-adjusted the trigger will stop not on the screw, but up against the microswitch inside the marker. This situation can cause damage to the microswitch and or circuit board.

The forward limit of the trigger's movement is adjusted by a 1/8-inch allen wrench. The forward trigger adjustment screw is located at the bottom of the trigger guard where it meets the grip frame. It may be helpful to remove the marker's rubber grips to provide easier access when making adjustments. Turning this screw clockwise decreases how far forward the trigger can move, while turning counterclockwise increases it. If the trigger is not adjusted to swing far enough forward, the microswitch inside the Envy™ will not be able to reset, resulting in the marker not firing.

Always check the trigger after making adjustments. Be sure that the trigger switch clicks when the trigger is pulled, and again when it is released. Also make sure that when the trigger is pulled it is being stopped by the rear trigger limit screw, not by pressing up against the microswitch inside the marker.

FIG. 8 → TRIGGER ADJUSTMENT POINTS

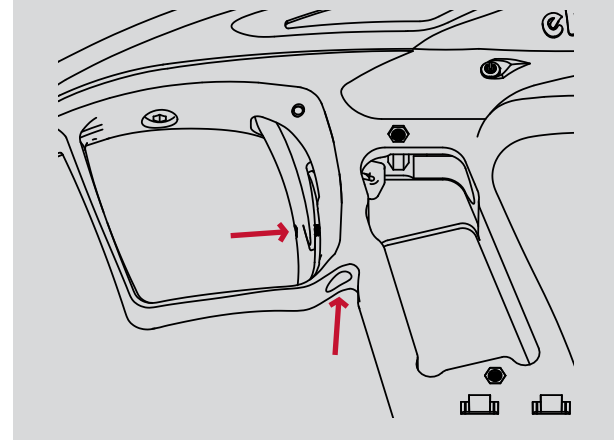

# FIRING MODES / DWELL

## NOTICE

Envy™ MARKERS MANUFACTURED FOR THE UNITED KINGDOM ARE LIMITED TO LOCKED SEMI-AUTOMATIC AND BILLY-BALL MODES IN ACCORDANCE WITH UK LAW.

## CHANGING FIRING MODES

Changing between firing modes is simple. Use a 5/64-inch allen wrench to open the left side grip panel. Remove and unplug the battery, taking care to pull the battery clip away from the battery, rather than pulling on the battery wires. Hold down the trigger while re-attaching the battery, and the marker's microprocessor will switch to a new mode, indicating the change by blinking the power LED. The number of times the LED blinks will indicate the newly selected mode. Replace the battery in the grip frame, carefully tucking in the wires, and re-secure the left side grip with a 5/64-inch allen wrench.

- **Select Fire** (Single Flash) - In this mode, the player can choose between semi-automatic (one shot per trigger pull,) 3-round burst (3 shots in a row fired while the trigger is pulled and held) or full-automatic (fires repeatedly when the trigger is pulled and held.) Tapping the power button while the marker is live cycles through the firing modes, each indicated by the rate at which the power LED blinks.
- **PSP** (Double Flash) - The marker will fire one shot per trigger pull until the trigger is pulled 3 or more times rapidly in quick succession, at which point it will fire additional shots per trigger pull up to a maximum of 10 shots per second. If the trigger is inactive for a brief time, the marker will revert to the beginning of the sequence, firing one shot per trigger pull, in accordance with PSP tournament rules adopted in 2009.
- **Locked Semi-Automatic** (Triple Flash) - The marker will fire one shot per trigger pull, and cannot be changed without using tools to open the grip. This mode complies with tournaments, fields and scenario games that limit players to semi-automatic mode only.
- **Billy-Ball** (Quadruple Flash) - This is a limited rate semi-automatic mode, firing one shot per trigger pull, but only allowing players to fire once every two seconds. Billy-Ball games focus on movement and strategy over heavy rate of fire, reducing paint costs.

## DWELL

The Envy™'s dwell setting determines how long it opens its solenoid valve to fire a shot. Because CO<sub>2</sub> expands differently than HPA, the optimal pulse length is different for each gas. The Envy™ is configured from the factory to use CO<sub>2</sub>. If you intend to use HPA, you must change your dwell mode in order to achieve best gas efficiency and battery life. With the marker unloaded and de-gassed, remove and unplug the 9-volt alkaline battery. Plug the battery back in while holding the power button down. The Envy™ will indicate that it has changed to HPA mode by double-blinking the power button LED and turning off. Reinstall the battery and grip panel. If you switch back to CO<sub>2</sub> as a power source, repeat the procedure, and the CO<sub>2</sub> dwell mode will be signified by a single blink pattern on the LED.

FIG. 11 CHANGING MODES

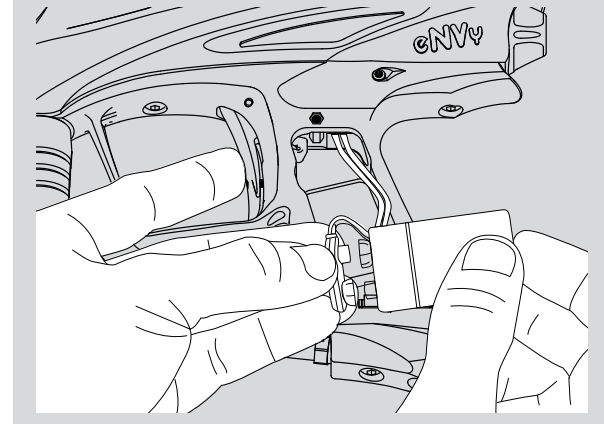

# UNLOADING/DE-GASSING

At the end of each day's use and before performing maintenance work on your Envy™, it will need to be de-gassed, and all paint removed.

In an area where it is safe to shoot (the chronograph area at a paintball field) and while wearing paintball goggles, remove the hopper from the Envy™. By turning the Envy™ upside down, you can empty any extra paintballs from the feedneck into your hand. Turn the Envy™ on.

Dry-fire 2 or 3 shots in a safe direction to ensure that no paintballs remain in the Envy™.

Continue to dry fire the Envy™ in a safe direction while turning off or unscrewing the HPA system or CO<sub>2</sub> tank, until all of the gas pressure inside has been released. At this point the only sound you should hear when you pull the trigger is the click of the solenoid valve. Turn off the Envy™.

If using a CO<sub>2</sub> tank or screw in HPA system, unscrew it the rest of the way.

PLEASE READ CAREFULLY

## //////////⚠WARNING

EVEN WITH NO CO<sub>2</sub> OR COMPRESSED AIR SYSTEM ATTACHED, THE ENVY™ MAY STILL HAVE ENOUGH GAS PRESSURE STORED IN THE REGULATOR AND FIRE CHAMBER TO FIRE 2 OR MORE SHOTS. YOU MUST DE-GAS YOUR ENVY™ BEFORE PERFORMING ANY MAINTENANCE PROCEDURES.

## //////////⚠WARNING

ALWAYS WATCH COMPRESSED GAS CYLINDERS TO MAKE SURE THAT THE CYLINDER AND VALVE ARE UNSCREWING FROM THE ASA, AND THAT THE CYLINDER IS NOT UNSCREWING FROM ITS VALVE. IF THE CYLINDER DOES BEGIN TO SEPARATE FROM ITS VALVE, STOP IMMEDIATELY, AND SEEK PROFESSIONAL ASSISTANCE.

# FIELD STRIPPING

## CLEANING

The valve system in the Envy™ has only one major moving part. Regular cleaning and lubrication is necessary to ensure accurate and consistent performance. The Envy™ should be field stripped, cleaned and lubricated any time it shows erratic performance, becomes contaminated with paint, dirt or other debris, or for general maintenance after 3 or 4 days of use.

Unload and de-gas the Envy™. Remove the barrel and use a 5/16-inch allen wrench to unscrew and remove the bolt sleeve from the back.

Using a soft, non-marring tool like a wooden chopstick or plastic toothbrush, push the bolt and bolt stop out the back of the Envy™. Clean the interior of the receiver, the bolt sleeve, bolt and bolt stop with a clean cloth or paper towel. Inspect their o-rings for signs of damage such as cuts or rips, and replace if necessary. Lightly lubricate all o-rings with GR33SE™ paintgun grease. Use GR33SE™ sparingly, as over-lubrication can cause the Envy™ to operate inconsistently. Slide the bolt stop onto the bolt from the rear. Slide the rear of the bolt into the bolt sleeve. Hold this entire assembly vertically with the front of the bolt pointing upward, and insert it up into the back of the Envy™. Screw the bolt sleeve into the back of the Envy™ by hand, taking care not to cross-thread it into the receiver.

Use the long end of a 5/16-inch allen wrench to turn the bolt sleeve until it is snug. As with the bolt sleeve, take care not to over-tighten these screws.

FIG. 12

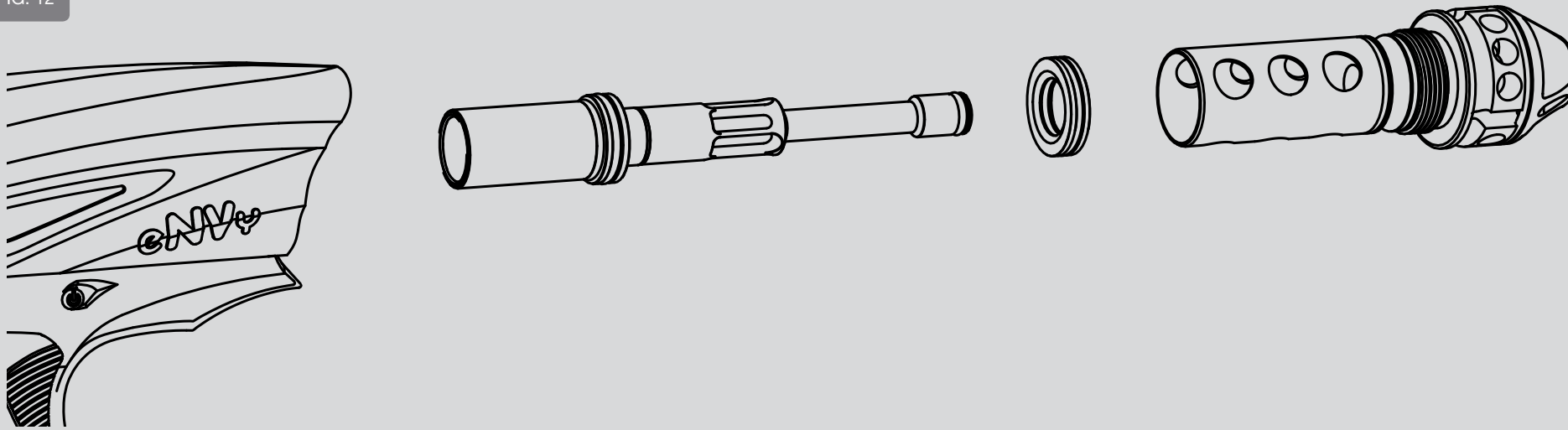

# ADVANCED MAINTENANCE

**NOTE:** Unload and degas the Envy™ before any cleaning or maintenance work.

The internal gas lines and electronic components of the Envy™ are well protected inside its body – however they are delicate and may be damaged by improper handling or re-installation. For this reason it is highly recommended that full disassembly of the Envy™ be performed by an airsmith with GOG Paintball™ factory training. Removal of internal hoses from their barbed fittings will stretch them to the point that they cannot be re-used without causing leaks.

Occasionally a more thorough cleaning of the Envy™ receiver is necessary to clean paint or debris that has worked deep into the breech, or to replace worn ball detents. Both are accessed through a complete disassembly of the receiver.

Unload and degas the Envy™, then field strip the valve system following the instructions in this manual.

Using a 1/8-inch allen wrench, remove the screws holding the ASA to the grip frame. Unscrew the vertical regulator from the receiver's vertical ASA. Take care not to lose the filter screen that is inside the vertical ASA.

Remove the rubber grip and battery, as when changing the battery. Use a 1/8-inch allen wrench to remove the front and rear grip frame screws. Carefully remove the grip frame from the receiver. Be aware that the clear power button fits loosely into its position in the side of the grip frame. Be careful not to drop or lose it. Watch to make sure the battery clip does not snag in the grip frame as the two parts are separated.

Reach the long end of a 1/8-inch allen wrench through the access hole in the top tactical rail, down into the head of the vertical ASA screw.

Unscrew the the two gas-through banjo bolts (indicated with arrows in Figure 15) using a 1/8-inch allen wrench. If the Envy™ has been upgraded with a circuit board featuring an anti-chop eye, unplug the wiring harness from the circuit board or anti-chop board (pull by the connector, not the wires) and lift the pneumatic control assembly off of the receiver.

FIG. 13 → GRIP FRAME REMOVAL

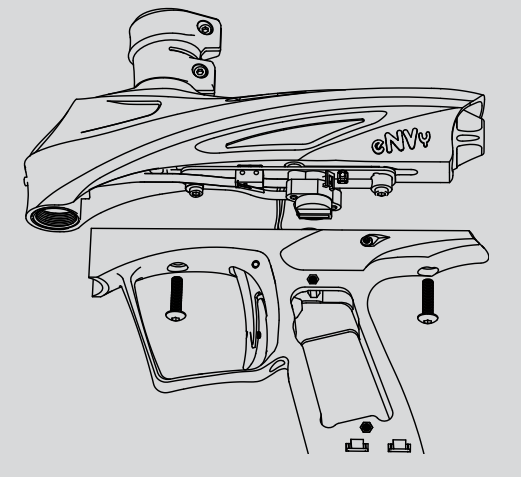

FIG.14 → BREECH SCREW REMOVAL

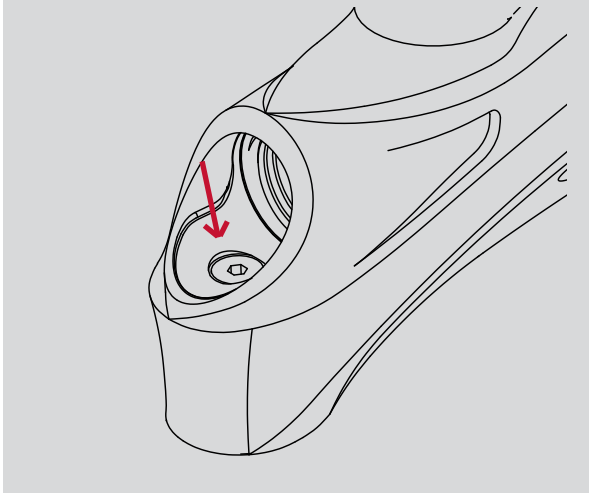
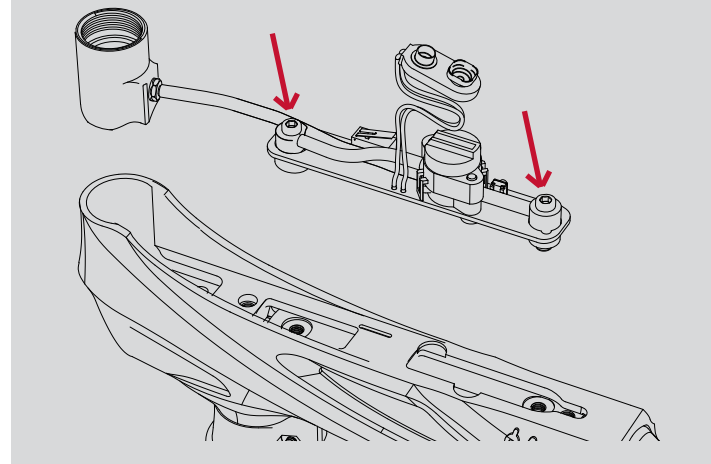

FIG. 15 → CIRCUIT BOARD REMOVAL



Slide the breech out the back of the receiver.

Both rubber ball detents should extend into the breech and show no rips or tears. If they must be replaced, they may be pried out with an o-ring pick, and pressed into place with a small allen wrench.

If the Envy™ has been upgraded with a circuit board featuring an anti-chop eye, holding the breech and receiver upside down will help the anti-chop circuit board remain seated while the parts are being reassembled.

When re-attaching the pneumatic control assembly to the receiver, take extreme care not to cross thread the fittings. Use the long end of the allen wrench to tighten the gas fittings and all screws, being careful to tighten them snug without over tightening.

## //////⚠️WARNING

Over-tightening or cross threading screws or fittings may result in permanent, nonrepairable damage to the breech.

Be sure to guide the battery clip down into the grip frame before re-joining the grip frame and receiver. Make sure the clear power button does not fall out of its place during reassembly.

Carefully tuck in all wires and hoses while rejoining the grip frame to the receiver.  
If the grip frame does not fit snugly to the receiver, pull the grip frame back away and look for hoses, wire, or improperly placed parts blocking the fit.

FIG. 16 → BALL DETENT REMOVAL

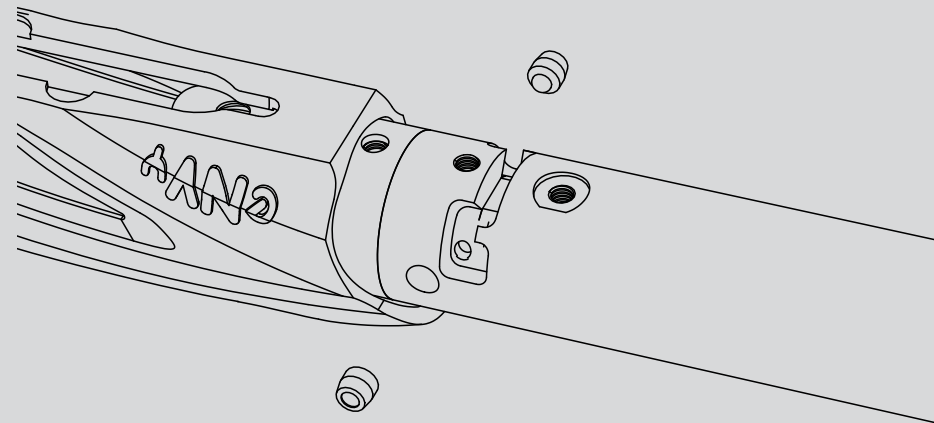

# VERTICAL REGULATOR

## REGULATOR SERVICE

Although explained here, regulator service should only be performed by a GOG Paintball™ trained airsmith.

With the marker unloaded and de-gassed, unscrew the regulator from the marker and remove the grip frame following the instructions in this manual. Take care not to lose the filter screen that sits inside the vertical regulator's ASA connection.

Using a pair of snap-ring pliers, remove the snap-ring from the bottom of the regulator and slide the regulator off the swivel. This is the preferred way to separate the regulator from the hose and bottomline ASA because it does not disturb the sealed hose fittings and is not likely to cause a leak.

Using a 7/16 open end or adjustable wrench, engage the wrench flats in the sides of the spring platform and remove it from the bottom of the regulator body. The regulator spring will now be free to fall out into your hand. The brass regulator piston may be removed by tapping the regulator body against a table top or solid, but soft surface such as a block of wood.

At this level of disassembly, the seal in the end of the piston and the regulator body may be inspected, cleaned with a soft cloth or cotton swab, and replaced if necessary. If the regulator seal shows signs of damage, it may be removed and flipped over so that its back side is used instead. If both sides of the seal are damaged, it must be replaced. Lightly lubricate all o-rings with GR33SE™ for reassembly.

Do not lubricate the regulator seal at the end of the piston.

## WARNING

SERVICE AND ADJUSTMENT TO THE REGULATOR WILL CAUSE CHANGES IN VELOCITY. ALWAYS RE-CHRONOGRAPH THE MARKER FOLLOWING THE PROCEDURE IN THIS MANUAL AFTER WORKING WITH THE REGULATOR.

FIG. 17 REGULATOR DISASSEMBLY

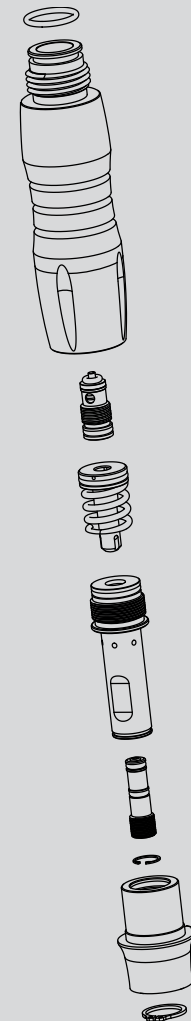



# VERTICAL REGULATOR

[ CONTINUED ]

## REGULATOR SERVICE, CONTINUED

The relief valve assembly should only be removed if it is constantly leaking. Occasional venting, especially if using CO<sub>2</sub>, is normal and does not indicate a leak. The relief valve assembly may be removed with a 5/32-inch allen wrench.

The velocity adjuster is located inside the lower end of the spring platform and similarly should only be removed if shown to be the source of a leak or clog. First the internal c-clip ring must be removed from inside the spring platform. This must be done with a pair of narrow snap-ring pliers. Some airsmiths have used bench grinders to re-shape standard snap-ring pliers for this task. The adjuster is equipped with left-hand threads and will need to be turned clockwise for removal. If regulator blockage is suspected, be sure to inspect, and if necessary, replace the inlet filter in the side of the velocity adjuster.

The vertical regulator is reassembled in the reverse order of disassembly. The piston slides into the regulator body wide end first, followed by the regulator spring. The spring platform should be tightened for a snug fit. Do not over-tighten. Re-attach the regulator swivel to the bottom end of the regulator and secure it in place with its snap-ring. Reinstall the assembled regulator into the marker. Re-adjust velocity after servicing the regulator.

## //////////▲NOTICE

THE RELIEF VALVE IN THE VERTICAL REGULATOR PROVIDES PROTECTION AGAINST PRESSURE SPIKES CAUSED BY SEAL FAILURE OR LIQUID CO<sub>2</sub>. REPLACING THE VERTICAL REGULATOR WITH ANY OTHER BRAND OR MODEL WILL BY-PASS AN IMPORTANT SAFETY FEATURE CREATING A RISK OF EQUIPMENT FAILURE OR INJURY AND INVALIDATING THE GOG PAINTBALL™ WARRANTY.

## MARKER IS LEAKING INTERNALLY

- Liquid CO<sub>2</sub> may cause temporary venting from relief valve or solenoid valve. This is normal, and does not require repair. If CO<sub>2</sub> is venting frequently, make sure the marker is properly configured to prevent feeding of liquid CO<sub>2</sub>.
- Pneumatic hoses may be loose, damaged or not fully connected. Replace hoses with genuine GOG Paintball™ hoses only.
- Hose has been disconnected and re-attached. Replace with a new GOG Paintball™ internal hose. Removing a hose stretches it so that it cannot be re-used without leaking.

## MARKER IS LEAKING DOWN THE BARREL

- One or more of the bolt or bolt stop o-rings are damaged or dirty. Inspect and replace if necessary, making sure to clean and lubricate the parts following the instructions in this manual.

## MARKER IS LEAKING FROM BOTTOMLINE ASA

- Unload and de-gas the marker. Inspect the CO<sub>2</sub> or HPA tank o-ring. Clean, lightly lubricate with GR33SE™ and if necessary replace.

## MARKER IS OCCASIONALLY LEAKING FROM THE VERTICAL REGULATOR

- Gas may occasionally vent near the top of the vertical regulator, especially when using CO<sub>2</sub>. This is a normal function of the relief valve protecting the marker, and does not indicate a problem. If CO<sub>2</sub> is venting frequently, make sure the marker is properly configured to prevent feeding of liquid CO<sub>2</sub>.

## MARKER EXHIBITS FIRST SHOT DROP-OFF (FSDO)

- FSDO is a low velocity, or non-firing first shot, followed by normal shooting and is often caused by debris in the bolt or a poorly lubricated bolt. Clean the bolt, breech, bolt stop and bolt sleeve, and lubricate them with GR33SE™ as instructed in the Field Stripping section of this manual.
- FSDO can also be caused using the CO<sub>2</sub> dwell setting with compressed air. Follow the dwell selection instructions in this manual and ensure that the correct dwell setting has been set for the type of gas being used.

## MARKER EXHIBITS INCONSISTENT VELOCITY OR DROPS OFF SIGNIFICANTLY DURING RAPID FIRING

- Check paint quality. Your marker is optimized for use with fresh, high-quality paintballs. Paintballs of inconsistent quality, or paintballs that have been exposed to humidity or temperature extremes may vary in size or roundness causing inconsistent operation.
- Gas could be low. Fill gas source and make sure gas supply is turned on.
- Battery may be low. This will be most noticeable with velocity dropping and then entire shots not firing during rapid fire. Replace battery with a new name brand alkaline battery.
- Regulator may be contaminated or damaged. Follow the instructions in this manual or see a GOG Paintball™ technician for service.
- Liquid CO<sub>2</sub> may be entering the regulator – see the gasses section of this manual for guidance in proper CO<sub>2</sub> set-up.

# TROUBLESHOOTING

## MARKER WILL TURN ON BUT WILL NOT FIRE

- Battery may be low or dead – replace with fresh name brand alkaline battery.
- The forward trigger limit adjustment screw may be set in too far, preventing the trigger from resetting. See the trigger adjustment section of this manual for guidance.
- The rear trigger limit adjustment screw may be set in too far, stopping the trigger before it can fire the marker. See the trigger adjustment section of this manual for guidance.
- Trigger switch may be damaged. Contact your dealer or GOG Paintball™ technical support.
- Regulator output pressure may be too high. Adjust the velocity to its lowest limit, then follow the velocity adjustment procedure in this manual.
- Liquid CO<sub>2</sub> may be entering the valve – see the gasses section of this manual for guidance in proper CO<sub>2</sub> set-up.

## MARKER IS BREAKING PAINT

- Use only fresh, high-quality paintballs. Poor quality paint, or paint damaged by humidity or temperature extremes during shipping or storage, will not perform well.
- Ball detents may be worn or damaged. Inspect, and if necessary, replace following the disassembly instructions in this manual.
- If the marker is equipped with an upgraded circuit board with anti-chop eye, the anti-chop function may be turned off. Turn anti-chop on, following the upgrade circuit board's instructions.

## IMPORTANT

### TECH SUPPORT

Our Technical Support Department can provide assistance via telephone. See our web site for phone number and tech support hours. Additional support and downloadable product manuals are available through our website at [GOGPaintball.com](http://GOGPaintball.com)

### WARRANTY

GOG Paintball SA warrants for (1) year to initial retail purchaser that the paintball marker and regulator are free from defects in materials and workmanship. Disposable parts (batteries, o-rings, springs, seals, etc.) are not warranted. The valve assembly, solenoid and electronics are warranted for 6 months. This warranty does not cover surface damages (scratches and nicks), misuse, improper disassembly and re-assembly, attempts made to drill holes or remove metal from the external surfaces which could degrade performance and reduce pressure safety factors of the marker. Do not make changes to the basic marker parts without written approval. The only authorized lubricant for the marker is DOW 33 lubricant. Use of any other lubricant could result in voiding your warranty. Paintball markers are non-refundable. This warranty is limited to the repair or replacement of defective parts with the customer to pay shipping costs. This warranty is effective only if the customer registers the product online @ [gogpaintball.com](http://gogpaintball.com) within 30 days of the purchasing the marker. The warranty is non-transferrable. Do not attempt to alter the trigger assembly in any way, as this will void your GOG warranty. Trigger alteration of any kind may result in serious injury.

# PARTS DIAGRAMS

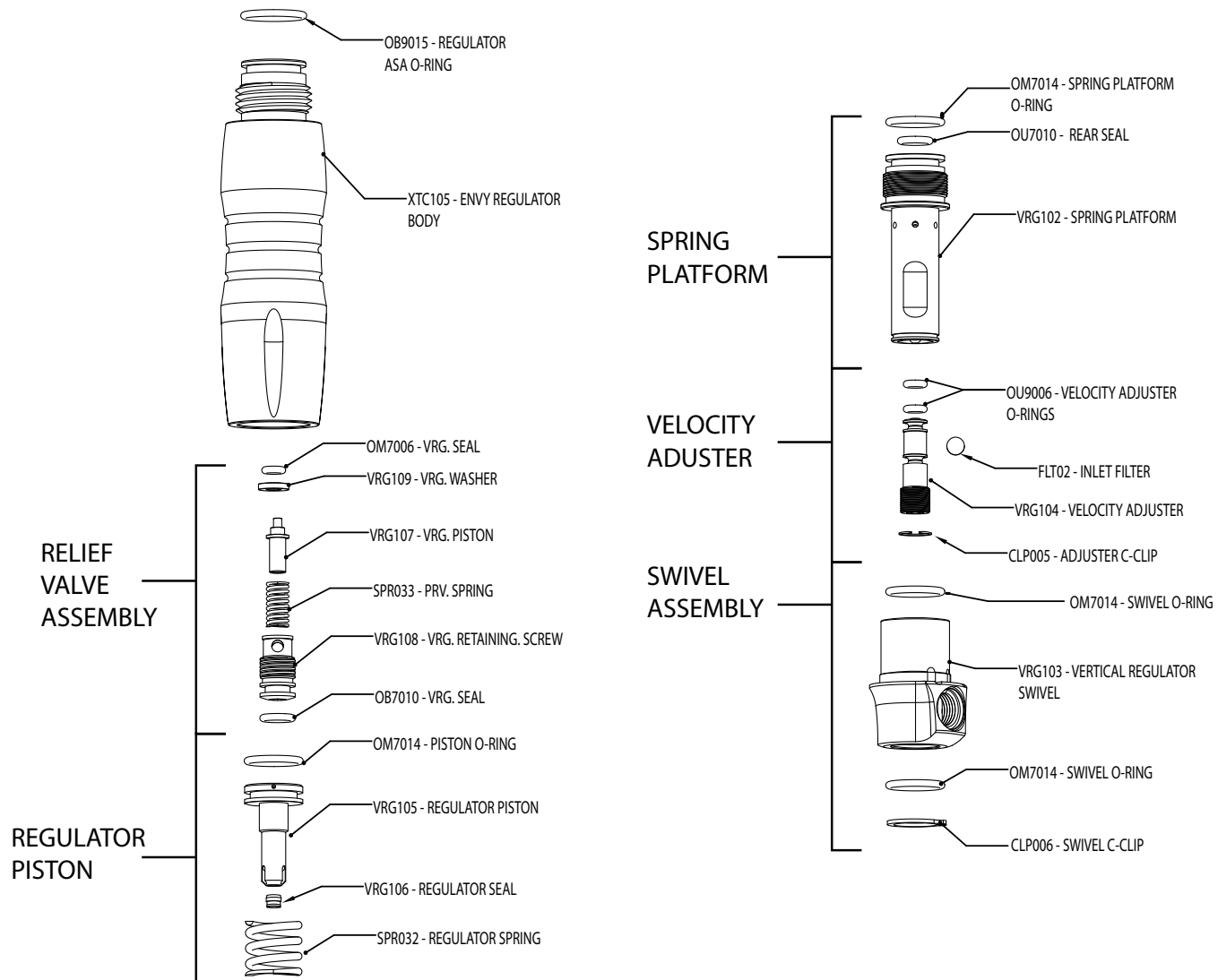

# PARTS DIAGRAMS

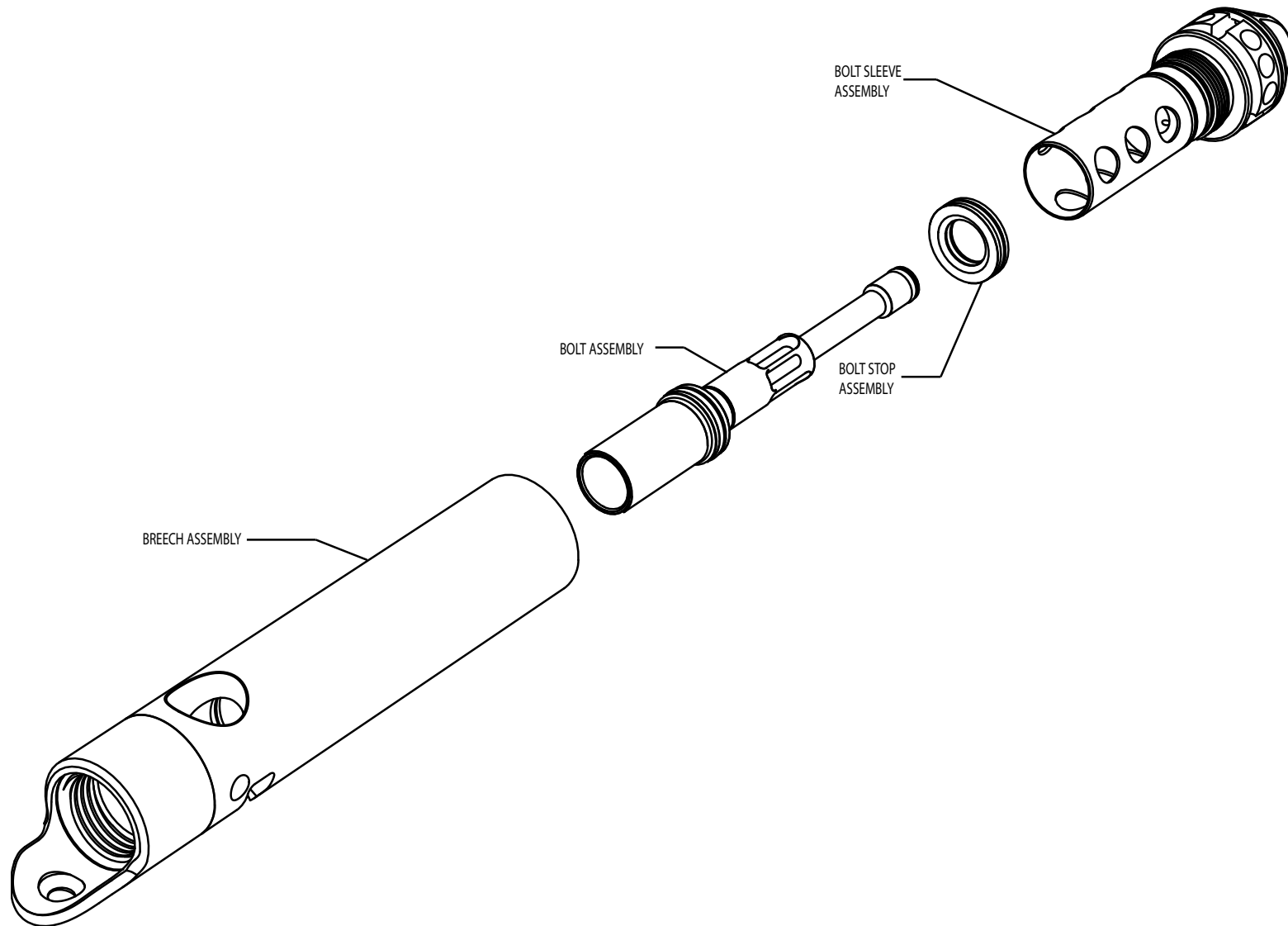

# PARTS DIAGRAMS

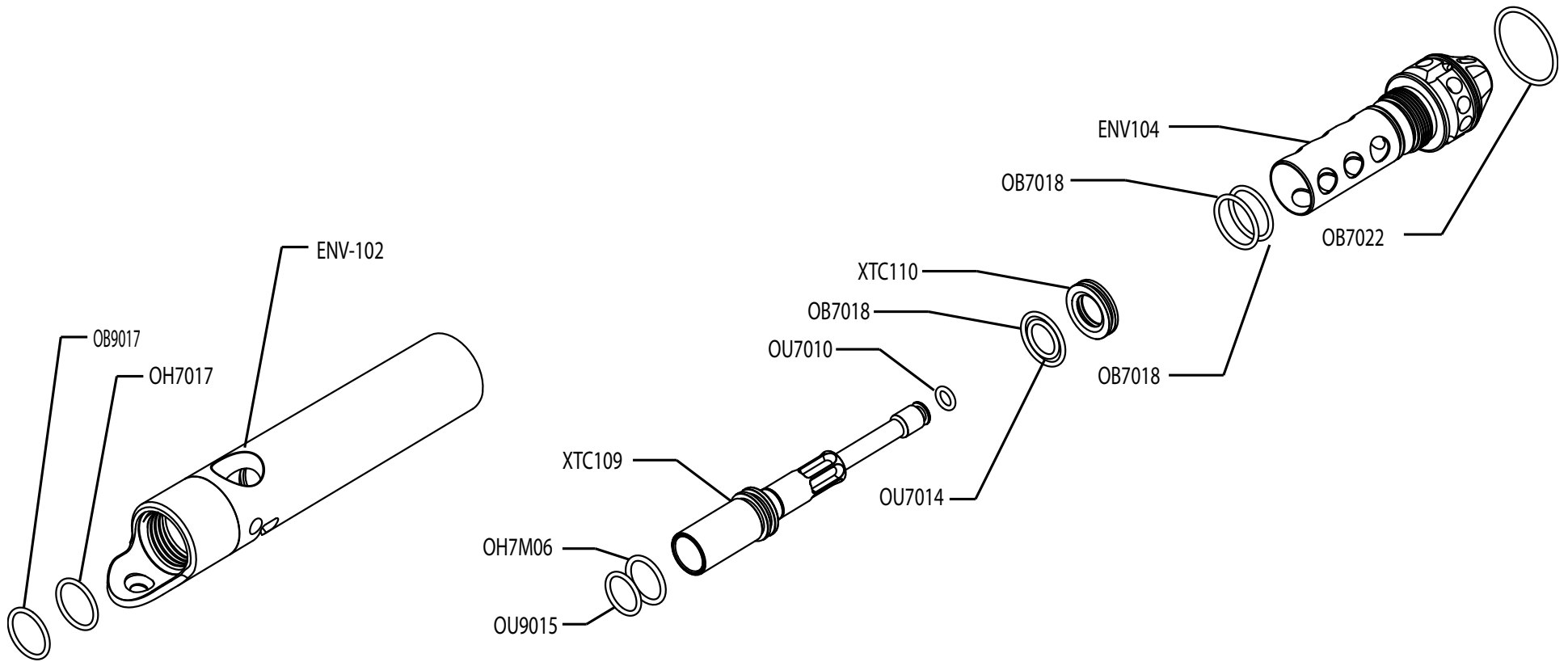

# PARTS DIAGRAMS

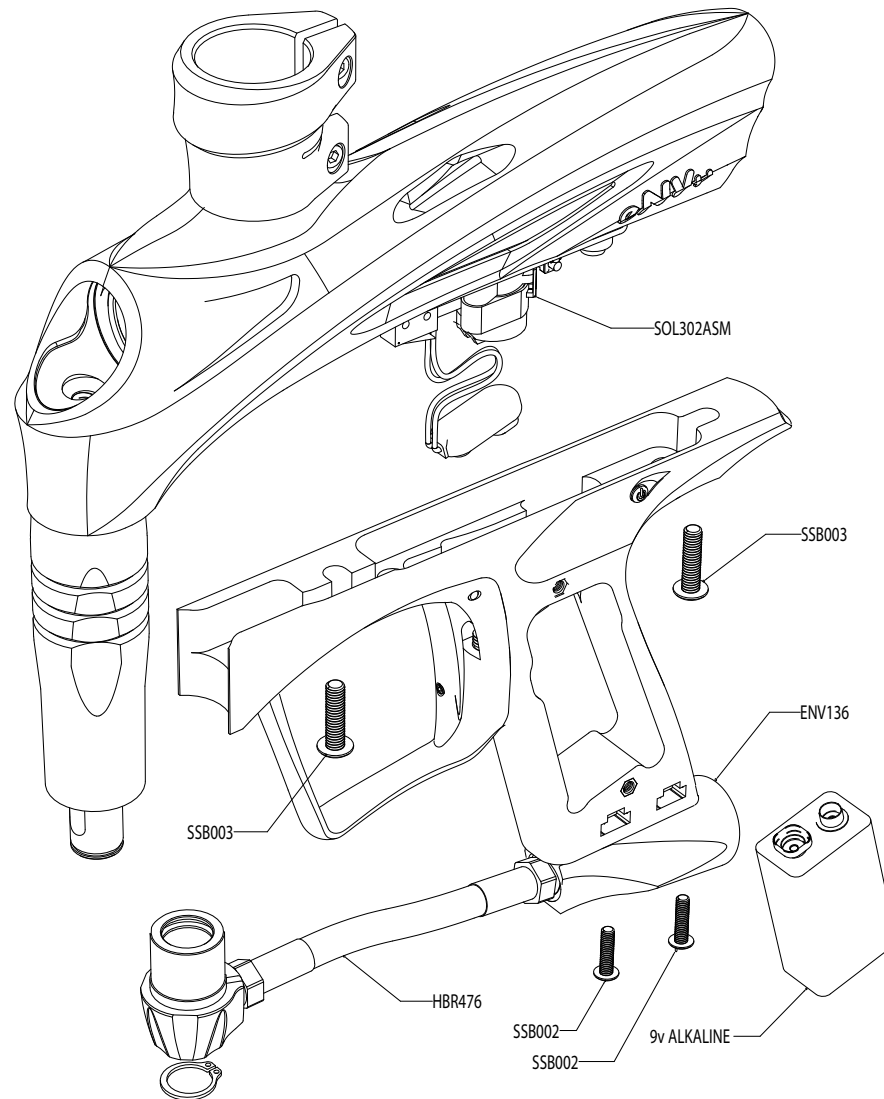



# PARTS DIAGRAMS

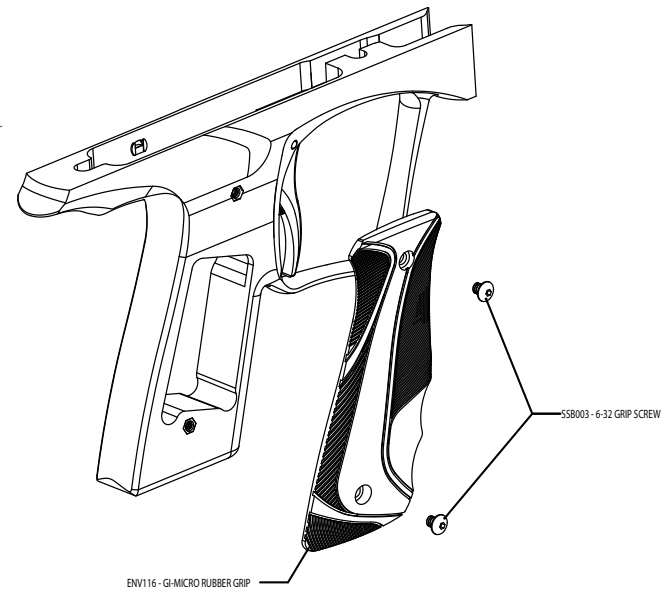
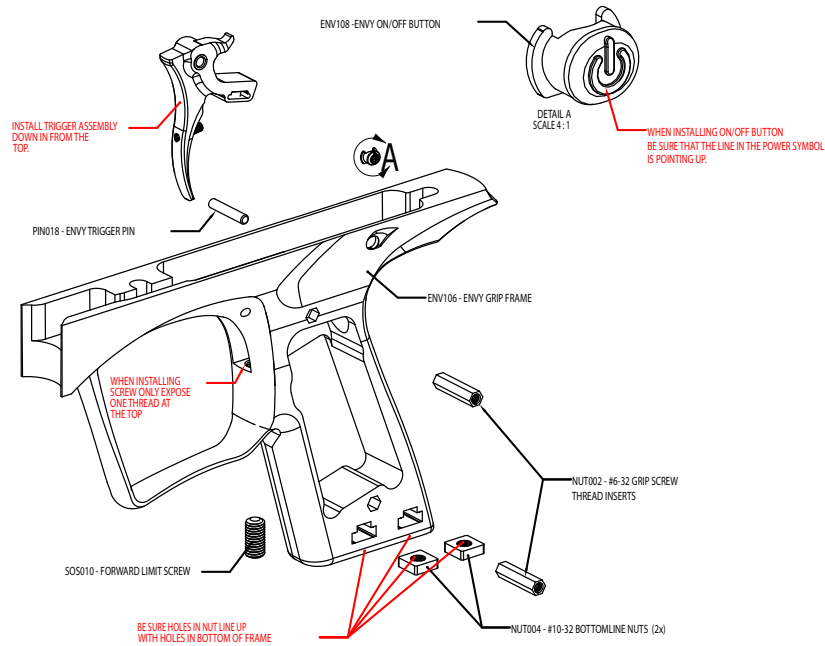
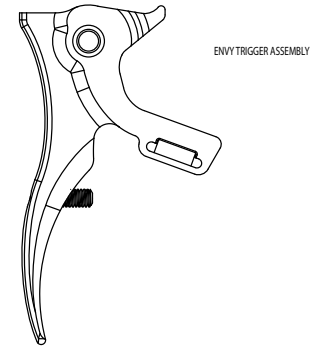
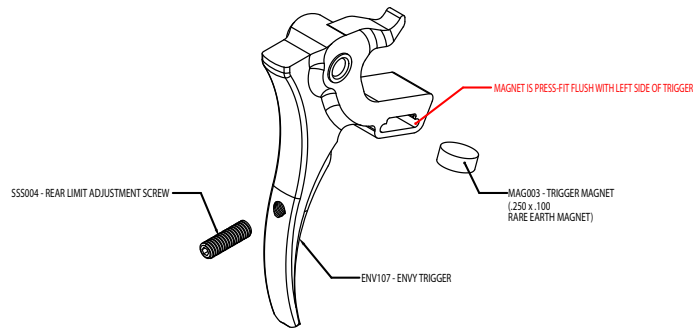

# PARTS DIAGRAMS

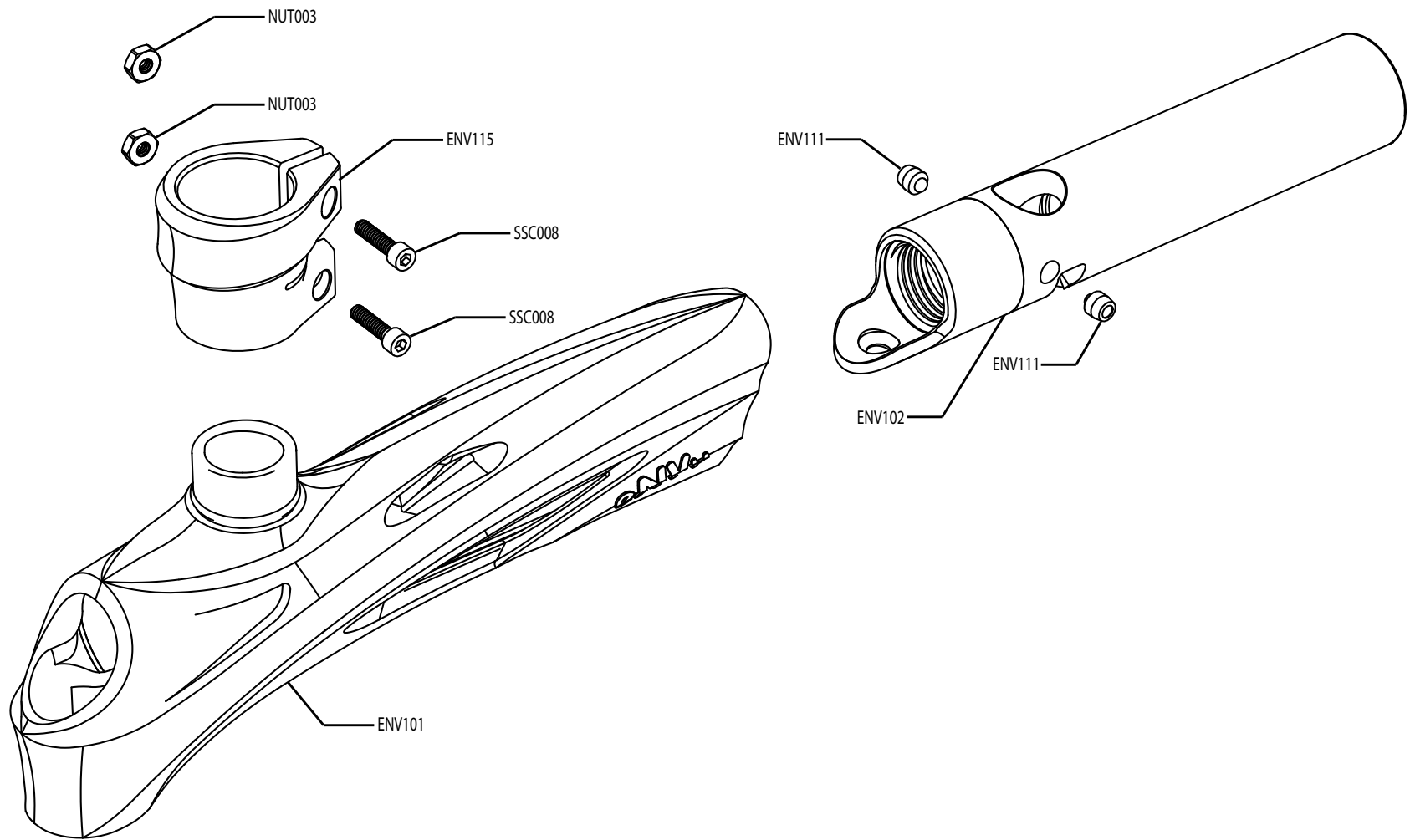



Envy™ Manual V1.02 © Copyright 2010, GOG Paintball, SA, all rights reserved.  
Envy, GR33SE, GOG, GOG Paintball and the GOG Paintball logos are trademarks or registered trademarks of GOG Paintball, SA.

[GOGpaintball.com](http://GOGpaintball.com)