

Operation and adjustment instructions

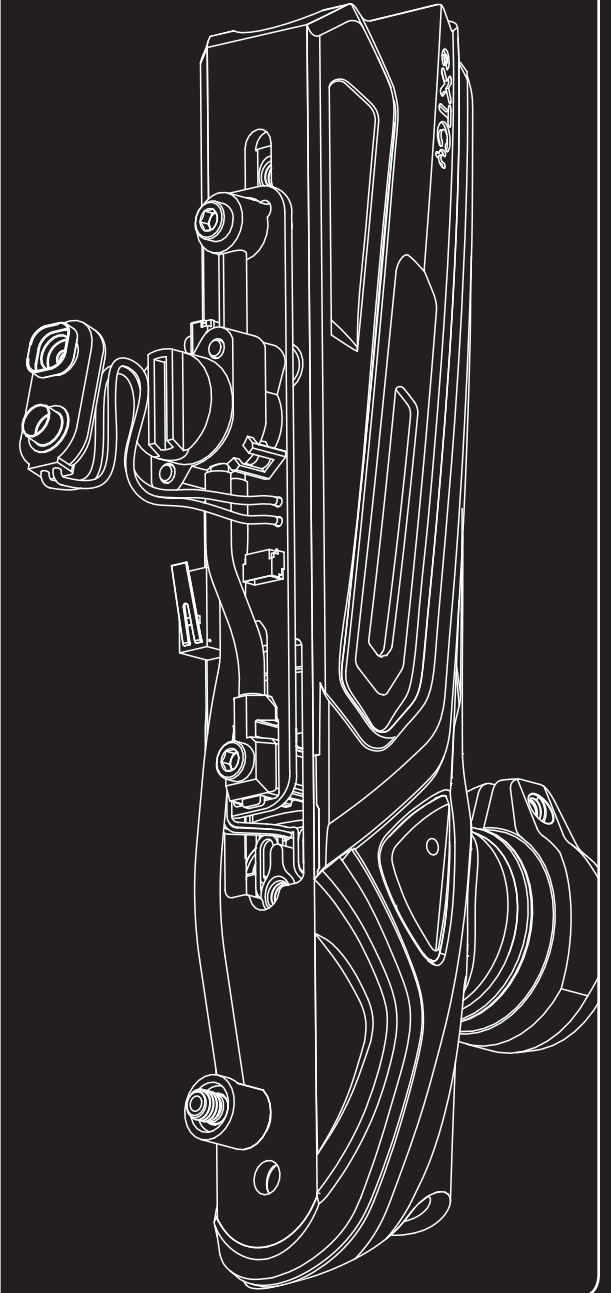
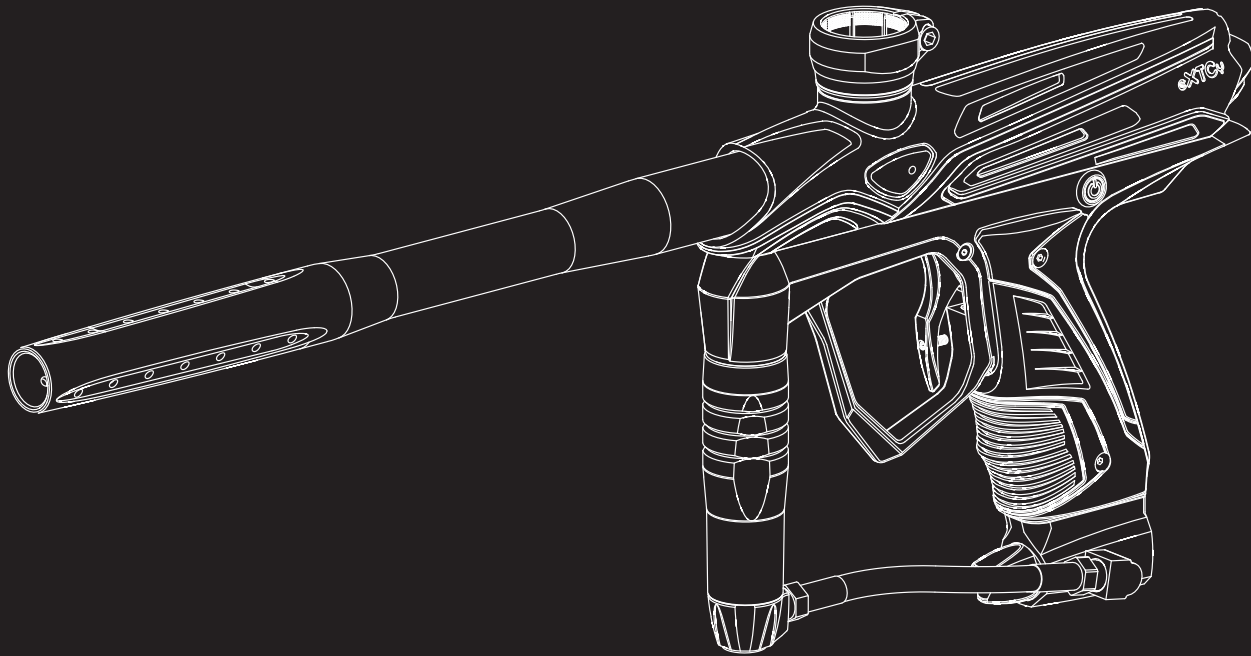

# QUICK START

## 01 BARREL

Unpack the eXTCy™ and its barrel. Screw the barrel into the front of the marker, hand tight. Take care not to strip the barrel threads or over-tighten.

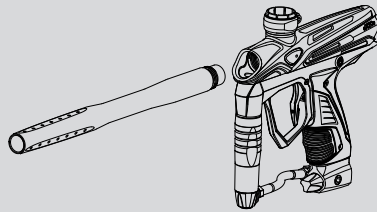

## 02 BARREL BLOCKER

Put the supplied barrel blocker over the end of the barrel, securing its cord as far back on the eXTCy™ body as possible, and cinching it tight.

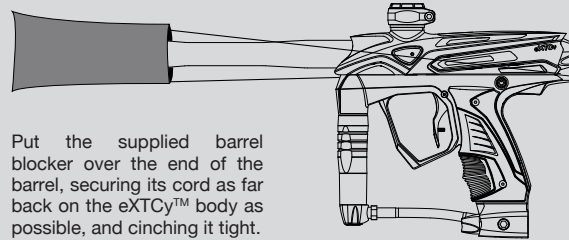

## 03 FILL TANK

Have your compressed air (HPA) or CO<sub>2</sub> tank filled by a person who is properly trained to do so. If using an HPA system with an on/off valve, make sure it is in the OFF position. If using a CO<sub>2</sub> tank or screw-in style pre-set HPA system, fill it while it is removed from the marker.

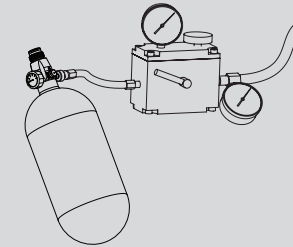

## 04 LOADER

Fit a paintball loader into the feedneck of the eXTCy™. Use a 7/64-inch allen wrench to lock the loader in place. Powered force-feed loaders are recommended, as the eXTCy™ has little recoil, and can easily outpace an unpowered or agitating loader.

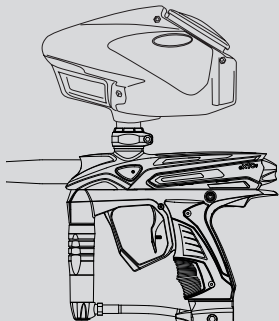

## 05 TURN ON GAS

Gently gas up the eXTCy™ by slowly turning on the air system (if HPA system has its own on/off valve) or turning the bottom-line ASA knob clockwise.

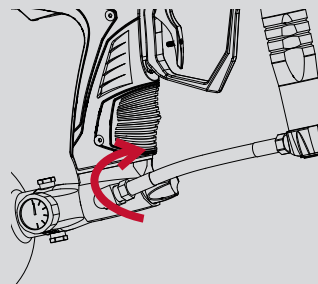

**WARNING**  
A gentle rise in pressure is important, as a sudden blast may reduce the service life of the eXTCy's internal components.

## 06 TURN ON THE eXTCy™

Turn on the eXTCy™ by pressing the power button momentarily. If the eXTCy™ does not start, see the battery section of this manual.

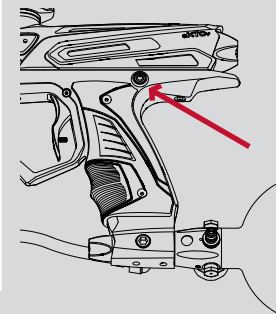

**WARNING**  
Although the power button serves as the eXTCy's safety switch to prevent accidental firing, it should never be relied upon in place of a barrel blocker and proper eye protection.

## 07 ADJUST VELOCITY

Fill the loader with paintballs. If it is a powered loader, turn it on. While wearing ASTM compliant paintball goggles, in an area where all bystanders are protected, remove the barrel blocker and fire over a chronograph to measure the velocity. Using a 5/32-inch allen wrench on the adjuster in the bottom of the vertical regulator, turn clockwise to increase the velocity/pressure, and counter-clockwise to decrease. Take three or four shots after every adjustment to allow the gas pressure inside the eXTCy™ to stabilize. Adjust until the marker is firing consistently within the limits for the field where you are playing (for safety reasons, never adjust the eXTCy™ to fire at greater than 300 feet per second). Depending on what modes of fire are allowed at the field where you are playing (semi-automatic, rebound, etc.) you may need to adjust the eXTCy's firing mode. See the Electronic Adjustment section for more information.

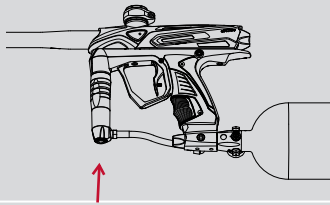

# TABLE OF CONTENTS

## WARNING

- THE eXTCy™ IS NOT A TOY.
- MISUSE OF THE eXTCy™ MAY RESULT IN SERIOUS INJURY OR DEATH.
- EYE PROTECTION DESIGNED FOR PAINTBALL USE MUST BE WORN BY THE USER AND ANY PERSON WITHIN RANGE OF THE eXTCy™.
- GOG PAINTBALL® RECOMMENDS THAT THE eXTCy™ ONLY BE SOLD TO PERSONS 18 AND OLDER.
- THOROUGHLY READ THE eXTCy™ OPERATION AND INSTRUCTION MANUAL BEFORE OPERATING.
- TREAT EVERY PAINTBALL MARKER AS IF IT WERE LOADED.
- NEVER LOOK DOWN THE BARREL OF A PAINTBALL MARKER.
- KEEP YOUR FINGER OFF THE TRIGGER UNTIL READY TO SHOOT. NEVER POINT THE eXTCy™ AT ANYTHING YOU DON'T INTEND TO SHOOT.
- KEEP THE eXTCy™ ON SAFE (POWER OFF) UNTIL READY TO SHOOT (SEE QUICK START).
- KEEP THE BARREL BLOCKING DEVICE ON THE eXTCy™'S MUZZLE WHEN NOT SHOOTING (SEE BARREL BLOCKER SECTION).
- ALWAYS REMOVE PAINTBALLS AND DE-GAS THE eXTCy™ BEFORE DISASSEMBLY (SEE DE-GASSING SECTION).
- STORE AND TRANSPORT THE eXTCy™ UNLOADED AND DEGASSED IN A SECURE PLACE.
- FOLLOW ALL MANUFACTURER'S WARNINGS AND INSTRUCTIONS FOR PROPELLANT SOURCE HANDLING, STORAGE AND FILLING.
- DO NOT SHOOT FRAGILE OBJECTS SUCH AS WINDOWS.
- ALWAYS MEASURE THE VELOCITY OF PAINTBALLS FIRED BY THE eXTCy™ BEFORE USE, AND NEVER ADJUST TO FIRE ABOVE 300FPS (91.44M/S).

<b>Quick Start</b>	<b>00</b>
Table of Contents and Safety Warnings	01
Getting Familiar	02
Barrel Blocker / Hopper	03
Gasses	04
Battery	06
Paint / Velocity	07
Vision™ Operation	08
Electronic Adjustment	09
Trigger Adjustment	13
Unloading / De-Gassing	14
Field Stripping	15
Vision™ / Detent Cleaning	16
Advanced Maintenance	
GripFrame / Body Separation	17
Circuit Board Removal	18
Breech Removal	19
Vertical Regulator	20
Troubleshooting / Warranty	22
Parts Diagrams	25

# GETTING FAMILIAR

PLEASE READ CAREFULLY

## → STATISTICS

WEIGHT:	1.85 lb
OPERATING PRESSURE:	160 psi
POWER SOURCE:	9-volt Alkaline Battery
PROPELLANT:	CO <sub>2</sub> or Nitrogen/Compressed air
RATE OF FIRE:	Uncapped Semi-Automatic - up to 20bps ramping / auto
OPERATION:	Low pressure electropneumatic
MODES OF FIRE:	12 modes incl: Semi, PSP, NPPL and Millennium
ANTI CHOP SYSTEM:	Vision™ Break-Beam eyes
BARREL THREAD:	GOG®
LUBRICANT:	For proper and consistent operation, the eXTCy™ should only be lubricated with GR33SE™ lubricating grease.

## MAINTENANCE

The eXTCy™ has been designed with simplicity in mind so that you can concentrate on your game instead of your marker. It has only one major moving part in its valve system, with a minimal number of seals. This DOES NOT mean that you should neglect your eXTCy™. If you take care of it off the field, your eXTCy™ will take care of you on the field. For best performance, clean and grease your eXTCy™ frequently. Many players disassemble and clean their eXTCy™ after every day of use. While this may seem a bit extreme, being vigilant in the upkeep of your eXTCy™ will extend its useful life considerably, and catch any problems when there is time to correct them before the next game. Playing in the rain will not damage your eXTCy™. In fact, the eXTCy™ has been tested and proven to function underwater. However, long-term exposure to moisture can cause rust damage to some of the eXTCy™'s screws, so if your eXTCy™ should become waterlogged, remove the barrel, stock, eye covers and rubber grips and allow it to dry out, then follow the disassembly instructions for full cleaning. Clean out mud and paint with a damp cloth and alcohol. Lubricate the eXTCy™ ONLY with GR33SE™ pneumatic grease. Use fresh, high quality paintballs for best performance.

## → REQUIRED ITEMS FOR USE

- 5/32-inch Allen Wrench (included) - Velocity Adjustment
- Chronograph (provided for use at commercial paintball field) - Velocity Adjustment
- Barrel Blocker (included)
- CO<sub>2</sub> or HPA tank (purchase separately)
- ASTM Compliant Paintball Goggles with Mask (purchase separately)
- 68 Caliber Paintballs
- Paintball Hopper/Loader (purchase separately)
- 9-Volt Alkaline Battery

## → REQUIRED ITEMS FOR MAINTENANCE

- 0.050-inch Allen Wrench (included) Trigger Adjustment / Vision™ Eye Covers
- 5/64-inch Allen Wrench (included) - Battery Change
- 7/64-inch Allen Wrench (included) - Clamping Feedneck
- 1/8-inch Allen Wrench (included) - Stock/Backplate, Trigger Adjustment, ASA, Grip, Breech and Circuit Board Screws
- 5/32-inch Allen Wrench (included) - Velocity Adjustment
- 5/16-inch Allen Wrench (included) - Bolt Sleeve
- Snap-Ring Pliers (purchase separately) - Regulator Disassembly (Advanced Maintenance)
- GR33SE™ (purchase separately) - Paintball Marker Lubricant

# BARREL BLOCKER/HOPPER

## BARREL BLOCKER

The Barrel Blocking Device is a critical piece of paintball safety equipment - nearly as important as paintball goggles. The Barrel Blocker serves to protect against accidental discharge of a paintball by catching it before it can cause harm. A Barrel Blocker is included with the eXTCy™ and must be used every time it is handled in an area where people or property are not properly protected by paintball goggles or paintball field netting. To use the Barrel Blocker simply slip it over the end of the barrel and stretch its cord back over the back of the eXTCy™ or the rearmost part over which it can be securely looped. Use the strap's adjuster to cinch the strap tight, so that the Barrel Blocker can provide protection against accidental discharge of a paintball.

## //////▲WARNING

The Barrel Blocker should only be removed when the eXTCy™ is on a “live” paintball field and all persons involved are wearing proper paintball protection.

## HOPPER

The eXTCy™ is a high performance tournament grade paintball marker. Its low-force bolt and Vision™ anti-chop system will prevent paintballs from being chopped if the hopper is not able to load paintballs as fast as the eXTCy™ is being fired. If you want to realize the eXTCy™'s maximum firepower potential, you will need to use a high performance loader. High performance loaders, especially those which provide force-feeding, will yield the best results with the eXTCy™.

The eXTCy™ is equipped with a clamping feedneck that allows it to adapt to the small size differences in hopper neck sizes, yet lock or release quickly. Using a 7/64-inch allen wrench, loosen the clamping feedneck before installing a hopper.

PLEASE READ CAREFULLY

FIG. 1 → BARREL BLOCKER IN USE

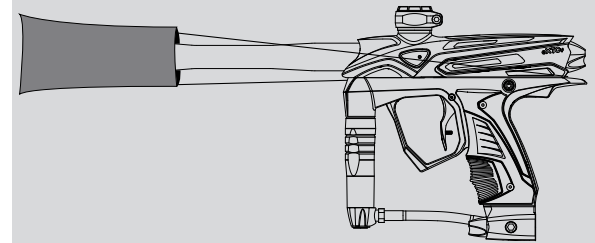
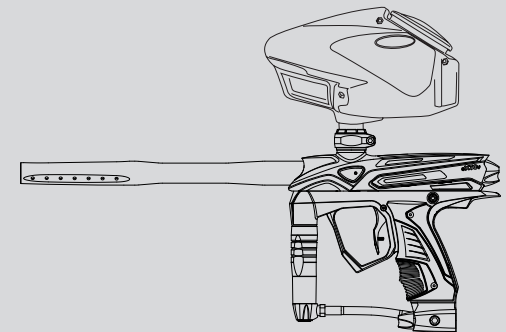

FIG. 2 → USE HIGH PERFORMANCE LOADER



# GASES

## COMPRESSED AIR

The eXTCy™ is a low-pressure paintgun. It operates at approximately 160 psi, which means it is capable of functioning well with either high-pressure compressed air or CO<sub>2</sub> as a power source. Proper set up of your gas system will help you obtain the best possible performance from your eXTCy™.

Whether using compressed air or CO<sub>2</sub> it is important that the eXTCy™ is not exposed to sudden “pops” of pressure. Always turn-on or screw-in a compressed air system or CO<sub>2</sub> slowly, so that the valve opens slowly and the gas pressure inside the marker is raised smoothly. Be gentle to the internals of your eXTCy™ and they will reward you with a long service life.

High Pressure Air systems (HPA) are the preferred power source used in paintball and with the eXTCy™ because they are unaffected by temperature fluctuations and do not have the potential for liquid problems. HPA systems consist of a tank and a regulator, and are typically rated to store air or nitrogen at pressures of 3,000 or 4,500 psi. Although pure nitrogen is almost never used in paintball, many players call compressed air “nitro” as air is made up of more than 70% nitrogen, allowing the two gasses to be used interchangeably in paintball equipment.

The eXTCy™ is configured for use with screw-in style HPA systems. Although HPA systems pre-set to deliver approximately 400 psi (low output) will work with the eXTCy™, 800 psi (high output) systems are preferred, to reduce the risk of gas starvation under rapid fire.

### //////////⚠WARNING

Never use oil or any petroleum based cleaner or lubricant in a compressed air regulator or tank. Exposure to pressurized air increases oil's flammability and can cause a serious safety hazard. Only use manufacturer recommended lubricants with compressed air systems, and follow the manufacturer's maintenance and operation instructions explicitly.

If you are using your eXTCy™ with an adjustable output compressed air system, it should be set to deliver about 800 psi. The eXTCy™'s vertical regulator can accommodate a wide range of input pressures, so exact adjustment of the air system is not critical.

### //////////⚠NOTICE

Due to shipping restrictions, CO<sub>2</sub> and HPA tanks are sold empty. They must be filled before they can be used. Most paintball shops and fields are equipped to fill HPA tanks. Paintball shops, fields, many hardware stores and sporting goods stores will have the equipment and trained personnel to fill paintball CO<sub>2</sub> tanks.

### //////////⚠WARNING

NEVER PUT OIL IN A COMPRESSED AIR REGULATOR OR TANK - ONLY APPLY MANUFACTURER RECOMMENDED LUBRICANTS.

FIG. 3 → HPA TANK BEING FILLED

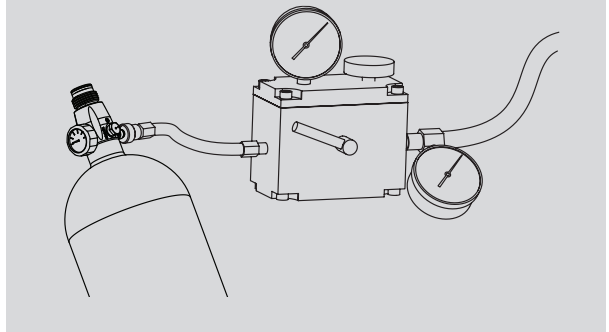

### //////////⚠NOTICE

The eXTCy™ is factory configured for use with CO<sub>2</sub>. Its dwell setting must be changed to obtain optimum performance with HPA. See the Firing Modes / Dwell section of this manual to learn how.

### //////////⚠NOTICE

Although the eXTCy™ can be powered by compressed air, typical home, garage or industrial air compressors cannot provide the high pressures required to fill a paintball HPA tank. Paintball HPA systems can be refilled by paintball fields and stores which use higher pressure compressors similar to those used in the SCUBA and firefighting industries.

# GASES

## USING CO<sub>2</sub>

CO<sub>2</sub> is usually not recommended for electronic paintball markers. This is not the case, however with the eXTCy™. The eXTCy™ can function extremely well with CO<sub>2</sub> as a power source, but doing so does require the correct configuration. The use of CO<sub>2</sub> will not damage the seals in the eXTCy™, freeze or cause damage to its circuit board.

The important thing to remember if using CO<sub>2</sub> is that best performance can be achieved when only gaseous CO<sub>2</sub> is fed to the eXTCy™, and liquid CO<sub>2</sub> remains in the tank.

Although the relief valve integrated into the eXTCy™'s vertical regulator provides the marker with protection from pressure spikes, those pressure fluctuations can cause poor performance, and temporary blockage of the eXTCy™'s solenoid valve.

The bottom-line ASA fitting on the eXTCy™ places the CO<sub>2</sub> level, like in Figure 5. When the marker is held in typical firing positions the liquid CO<sub>2</sub> will pass through the valve into the marker unless an anti-siphon system is used.

Anti-siphon CO<sub>2</sub> tanks contain a J-shaped tube that draws gaseous CO<sub>2</sub> from the top of the tank when it is in a horizontal position. Anti-siphon tubes must be professionally installed, to ensure that critical safety checks are performed during valve installation. Anti-siphon CO<sub>2</sub> tanks should not be used with remote hoses.

Alternative CO<sub>2</sub> arrangements include placing the CO<sub>2</sub> tank vertically in a pack, and using a paintball remote hose to feed CO<sub>2</sub> to the eXTCy™. This arrangement not only prevents liquid CO<sub>2</sub> from entering the marker, but also makes the marker assembly lighter weight. Another possible configuration is to use a third-party ASA or ASA mounting adapter which mounts a standard CO<sub>2</sub> tank at an angle like in Figure 4. In this arrangement gravity keeps the liquid CO<sub>2</sub> below the valve neck.

## BOTTOM-LINE ASA

The bottom-line ASA fitting on the eXTCy™ can be removed by unscrewing the two industry-standard 10-32 mount screws holding it to the grip frame after unscrewing and removing its on/off knob. If replacing the ASA, be sure the model chosen takes into account the type of gas system being used (horizontal for anti-siphon CO<sub>2</sub> tanks or compressed air, angled for standard CO<sub>2</sub> tanks).

PLEASE READ CAREFULLY

FIG. 4 → ANGLED CO<sub>2</sub> [CUTAWAY VIEW]

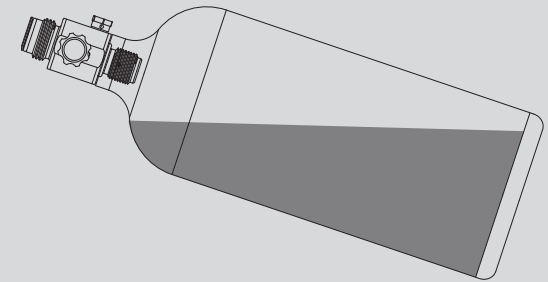
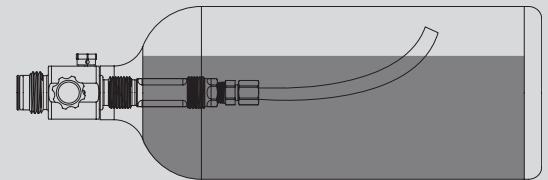

FIG. 5 → CO<sub>2</sub> WITH ANTI-SIPHON [CUTAWAY VIEW]



## IMPORTANT

CO<sub>2</sub> may also be configured with a remote hose with-out Anti-Siphon. [Not Shown]



# BATTERY

## BATTERY

The eXTCy™ is powered by a standard 9-volt alkaline battery. Lower cost “heavy duty” batteries will not consistently deliver the amperage needed to operate the eXTCy™ reliably. Erratic performance, especially drops in velocity or skipped shots during rapid fire can result from a battery that is not delivering full power.

The eXTCy™ is also compatible with 9-volt rechargeable batteries. Because specifications of batteries vary widely from brand to brand, use of any rechargeable battery will require testing to determine if it can power the eXTCy™ reliably and fit correctly in the grip frame. Some NiCD “9v” rechargeable batteries actually operate at 7.2 volts. These types of batteries will not work well with the eXTCy™.

Each time the eXTCy™ is turned on, the power button LED will blink 5 times rapidly, with its color indicating the estimated charge level of the battery. Green indicates a charge level between 75% and 100%. Yellow denotes a charge level between 50% and 75%, while red flashing indicates that the remaining charge is estimated to be below 50%. It is important to note that different types and even brands of rechargeable batteries will give different readings than alkaline batteries., so experience will be the best teacher as to how much remaining use to expect once a reduced charge level is indicated.

Any time the eXTCy™ exhibits erratic performance, drops velocity or skips shots while rapid firing, does not shoot or does not turn on, the first step in troubleshooting should *always* be to replace the battery with a *brand-new, name-brand alkaline battery*.

To replace the eXTCy™ battery, use a 5/64-inch allen wrench to remove the two screws from the left side of the rubber grip, then open the grip. Be careful opening the grip from the grip frame. Folding the grip back around the trigger frame may seem convenient, but may cause tearing or stretching in the center of the grip, which will cause it to pucker or fit poorly when reinstalled. As an alternative to folding the grip open, simply remove it entirely by removing the two grip screws from its right side.

Remove the old battery, taking care not to bend, kink or strain its wires. Unsnap the battery from its connector by pulling on the connector, not the wires. Snap in a fresh battery, then place that in the grip frame, tucking the wires into place, before closing and re-securing the grip. The battery and connector should fit snugly in the battery space, so that they do not shift around during use. Some off-brand batteries may be too large to fit correctly in the grip frame. If this is the case, do not force the battery into position, instead replace it with a name-brand alkaline battery.

## WARNING

OVER TIME BATTERIES MAY LEAK. ALWAYS REMOVE THE BATTERY FROM THE eXTCy™ WHEN STORING FOR MORE THAN A MONTH.

FIG. 6 → ALKALINE BATTERY

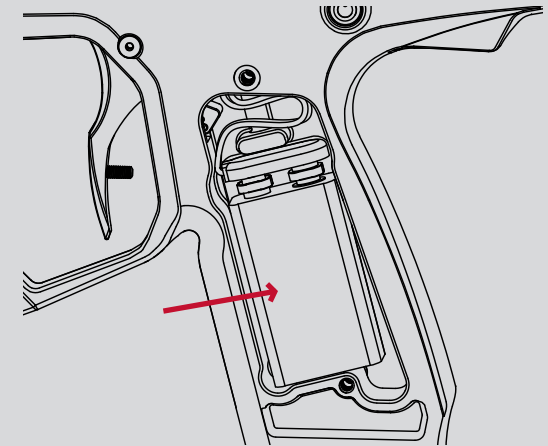



# PAINT/VELOCITY

## PAINT

Even the best quality paintballs will vary in size from one batch to the next and as weather conditions change. While your eXTCy™ will work well even with a poor paint to barrel fit, optimal performance will be achieved with a proper fit.

The ideal fit between the paintball and the barrel is when the ball is inserted in the bore (the end that screws into the eXTCy™) and does not slip or roll through to the muzzle (the business end) on its own. The ball should sit in place, even when the barrel is pointed straight down. If the paintball can roll out on its own, the fit is too loose. The ball should be able to be expelled from the barrel by blowing it out, like a blowgun, using a minimal amount of breath. If the ball is difficult to blow through, the fit is too tight, which can lead to ball breakage.

If the paintballs available at your field do not fit well in the eXTCy™, the use of sized barrels, such as TheFreak® barrel system can quickly adapt the marker for optimum performance with changing paint conditions.

## VELOCITY

The velocity, or speed at which a paintball is fired from the eXTCy™, must be measured and adjusted to below the paintball field's velocity limit immediately before each day of play (for player safety). If CO<sub>2</sub> is used, velocity should be checked and adjusted multiple times during the day.

In an area where it is safe to fire paintballs, while wearing ASTM compliant eye and face protection for paintball, fire three or four shots over a chronograph to measure the velocity at which the paint is being fired.

If velocity adjustment is necessary, use a 5/32-inch allen wrench on the adjuster in the bottom of the vertical regulator, turn clockwise to increase the velocity/pressure or counter-clockwise to decrease. Take three or four shots after every adjustment to allow the gas pressure inside the eXTCy™ to stabilize, then measure velocity again. Adjust until the marker is firing consistently within the limits for the field where you are playing. For safety reasons, never adjust the eXTCy™ to fire at greater than 300 feet per second (91.44 meters per second).

## WARNING

NEVER ADJUST THE eXTCy™ TO FIRE ABOVE 300 FEET PER SECOND, AS SERIOUS INJURY MAY RESULT.

FIG. 7 → VELOCITY ADJUSTMENT

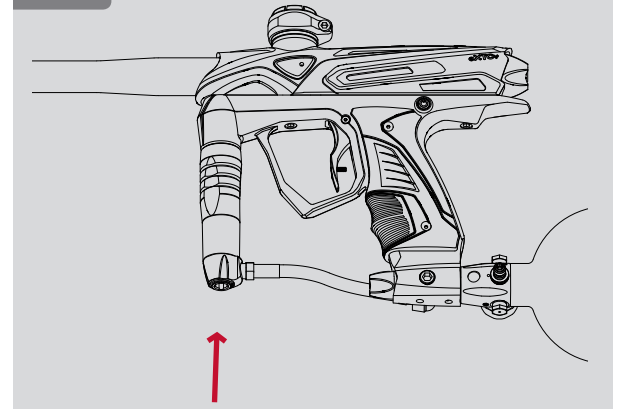

# VISION™ OPERATION

## VISION BYPASS

The eXTCy™ is equipped with a Vision™ break-beam anti-chop system, allowing it to achieve the highest possible rates of fire without chopping or mis-feeding paintballs.

The eXTCy™ circuit board is linked to a light emitting diode and detector installed in the marker's breech. When a paintball drops down the feedneck into the breech, it breaks the light beam and the eXTCy™ circuit board detects its presence. When the Vision™ system is activated, the eXTCy™ will not fire until it "sees" a paintball in the breech. This prevents the marker from dry firing or from chopping a paintball in half by firing before the ball is completely loaded.

There may be times when it is desirable to bypass the Vision™ system, such as dry-firing the eXTCy™ to test electronic adjustments, or when de-gassing.

While the eXTCy™ is turned on, pressing and holding the power button for approximately one-half second will turn the Vision™ system off, allowing the marker to fire whenever the trigger is pulled, whether or not there is a paintball in the breech. Pressing for approximately a half second will also turn Vision™ back on.

When Vision™ is on, the power button will glow green. When it is off, the button will glow red.

FIG. 8 → VISION™ DE-ACTIVATION

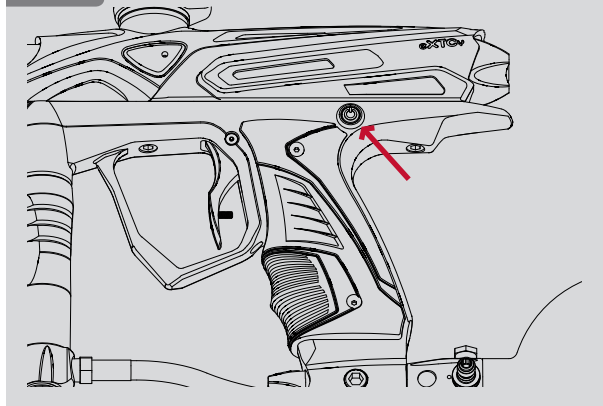

# ELECTRONIC ADJUSTMENT

## //////▲WARNING

ALL EXTCy™ PROGRAMMING AND ADJUSTMENT MUST BE PERFORMED WITH THE MARKER UNLOADED AND DE-GASSED.

## LOCKING/UNLOCKING

Most paintball tournaments, scenario games and fields have rules which do not allow a player to make adjustments that can affect velocity (such as dwell) or change firing mode settings during a game. These rules require that a marker be locked so that such adjustments can not be made without using tools, which are not allowed on-field.

To lock or unlock the eXTCy™, following the battery replacement directions in this manual, remove the wraparound rubber grip, unplug and remove the marker's 9-volt battery. Hold down the trigger while plugging the battery back in. The power LED will light red to indicate that the Blackheart board is locked, or green to indicate that it has been unlocked. Repeat the procedure to lock or unlock the marker.

## ENTERING PROGRAMMING MODE

Changes are made to the eXTCy™'s electronic settings in programming mode. To enter programming mode, press the power button to turn on the marker while pressing and holding the trigger back. Once in programming mode, pull the trigger to cycle through the available parameters, which are indicated by the color and blinking of the power button LED. If the marker will not switch into programming mode, the eXTCy™ is locked. The board will need to be unlocked before changes can be made.

When the desired parameter is selected, enter its new value by pulling and holding the trigger until the power LED turns off, then pulling the trigger a number of times corresponding to the desired setting. The LED will blink a number of times to confirm the new value that has been set. To exit programming mode, press the power button, turning the marker off.

## PROGRAMMING EXAMPLE

To change the eXTCy™'s BPS Cap to 13 bps, make sure the marker is unloaded, de-gassed and unlocked.

Enter programming mode by turning the eXTCy™ on while holding the trigger back. Release the trigger when the power button blinks fast red.

Pull the trigger three times, waiting between each pull to see what color the power button LED is flashing. After the third pull, the power button will be flashing red, indicating that the ROF Cap has been selected.

Press and hold the trigger until the power button stops glowing. Pull the trigger 13 times to set the ROF Cap value to 13 balls per second.

Wait, and watch as the power button blinks 13 times to confirm the 13 BPS value.

Press and hold the power button until it stops glowing to turn the eXTCy™ off.

Once programming is complete, re-lock the eXTCy™ so that it will be "field legal."

Note: The BPS Fine setting must be at 0 for a BPS cap of 13 to yield a maximum rate of 13.0 balls per second. See BPS Fine Setting for more information.

# ELECTRONIC ADJUSTMENT

NOTE: THE UK VERSION OF THE eXTCy™ IS LIMITED TO THE FOLLOWING MODES: 1 SEMI-AUTOMATIC, 2 CAPPED SEMI, 3 MILLENNIUM, 4 BILLY BALL™

**FIRING MODES** (Power Button LED Glows solid red) - Sets Firing Mode:

- 1 - Semi-Automatic:** This mode fires one shot per trigger pull, as fast as the trigger is pulled. The BPS cap has no effect on Semi-Automatic mode. This is the default firing mode for the eXTCy™.
- 2. Capped Semi-Automatic:** This mode operates the same as semi-automatic, but is limited by the BPS Cap setting.
- 3. NXL:** Fires one shot per trigger pull until the trigger is pulled three times in quick succession, at which point it operates as if in fully automatic mode, firing repeatedly as fast as the Vision™ and BPS Cap will allow, until the trigger is released for a moment, at which point the cycle begins again firing one shot per trigger pull.
- 4. PSP:** Fires one shot per trigger pull until the trigger is pulled three times in quick succession at which point it switches into a ramping mode firing more than one shot per trigger pull while the player pulls the trigger repeatedly. After one second of inactivity PSP mode reverts to its beginning single shot per pull operation.
- 5. Millennium:** Fires one shot per trigger pull until the trigger is pulled at a rate of 8 times per second or faster, at which point it begins firing more than one shot per trigger pull. When the user pulls the trigger at rates below 8 times per second, Millennium mode reverts to firing one shot per trigger pull.
- 6. CFOA:** Fires one shot per trigger pull until the trigger is pulled three times at a rate of 5.5 times per second or faster at which point more than one ball is fired per trigger pull, until the rate of trigger pulls drops below 5.5 per second, at which point CFOA mode reverts to firing 1 shot per trigger pull.
- 7. Auto Response:** Fires on both the pull and release of trigger.
- 8. Select Fire:** Allows for in-game selection between semi-automatic, burst and full-automatic firing modes without the use of tools, during a game. When using Select Fire mode, the power button LED will indicate which of the three modes is operational. The LED will glow solid for semi-automatic, blink slowly for burst mode or rapidly for full-automatic. Pressing the power button quickly will cycle through the three modes.
- 9. Burst:** Fires a user selected number of shots each time the trigger is pulled and held.
- 10. Full-Automatic:** Fires when the trigger is pulled and continues firing repeatedly at a rate defined by the BPS Cap and Vision™ system until the trigger is released.
- 11. Rebound™:** Begins firing one shot per trigger pull, but begins firing more than one shot per trigger pull as the player pulls the trigger more rapidly, reverting to one shot per trigger pull when the rate of trigger pulls decreases.
- 12. Billy-Ball™:** This mode restricts eXTCy™'s rate of fire to make it less intimidating to new paintball players, or create an even playing field with pump-action paintguns. Billy-Ball™ also can be used by experienced players to train for reliance on stealth, accuracy and movement instead of of rate of fire.

## FACTORY RESET

The eXTCy™ can be quickly and easily reset to its factory-default settings. This is can be an important step in diagnosing unusual firing patterns of behavior on the field, especially if using a marker that was previously adjusted by someone else.

To reset the eXTCy™, first unload and de-gas the marker following the instructions in this manual, and make sure the circuit board is unlocked.

With the eXTCy™ turned off, pull the trigger, then press the power button while continuing to hold the trigger back. Continue holding the trigger for ten seconds until the power button LED flashes white. Release the trigger and all programming parameters will have been reset to their factory default values.

# ELECTRONIC ADJUSTMENT

**VISION™** (Power Button LED glows solid green) - Sets how the Vision™ system operates:

- 1. Classic:** The marker will not fire unless there is a ball in the breech, breaking the Vision™ beam. This is the default Vision™ mode.
- 2. Delayed:** If the breech is empty when the trigger is pulled, the marker will wait up to ½ second for a ball to load before the marker fires. At the end of the delay period, the eXTCy™ will fire, even if no paintball is detected. Delayed mode effectively allows the eXTCy™ to fire “blind” at a reduced rate of fire if the Vision™ system is fouled by debris or paint.
- 3. Forced Delay:** This mode works the same as the Classic Vision™ mode, but may also fire when the breech is empty, by holding the trigger down for a full second. Forced delay mode allows for easy de-gassing of the eXTCy™ without having to switch Vision™ off.

**DWELL:** (Power Button LED glows solid yellow) - Adjusts how long the solenoid valve is held open to fire each shot. Dwell is adjustable from 5 to 65 milliseconds in 1 millisecond increments. Raising dwell can improve shot to shot consistency and protect against shoot-down (drops in velocity when rapid firing). These symptoms are most common when using CO<sub>2</sub> as a power source. Raising the dwell higher than necessary can reduce the eXTCy™'s maximum rate of fire by causing the bolt to stay forward longer than necessary. The recommended dwell settings on the right are selected to allow the highest possible rates of fire while maintaining reliable operation. Also, when using a 9.6 volt rechargeable battery and HPA, lower dwell times may be used to extend battery life. When experimenting with lowered dwell settings, velocity drop-off during rapid firing, skipped shots or first-shot drop-off are all signs that the dwell must be increased.

**BPS Cap:** (Power Button LED blinks fast red) - In all firing modes except semi-automatic and Billy-Ball™, this setting limits the eXTCy™'s maximum rate of fire. BPS cap is adjustable from 4 to 20 balls per second in 1 bps increments. The default value is 13 bps.

**BPS Fine Adjust:** (Power Button LED blinks fast green) - This parameter allows for fine-tuning of the BPS cap by adding a small value to it. Settings from 1 to 9 add from 0.1 to 0.9 bps to the BPS Cap. For example, setting BPS Cap to 13, and BPS Fine Adjust to 2, will result in a maximum rate of fire of

## ZERO VALUE

When setting a whole BPS number for the maximum rate of fire, or turning off FSDO compensation, values of zero must be set.

To set a value of zero, once the Power Button LED is blinking to indicate the desired parameter, pull and hold the trigger to select, then do nothing, and the eXTCy™ will accept zero as the new value.

## RECOMMENDED DWELL

The optimal dwell setting depends on the configuration of the eXTCy™. The following dwell values are recommended for each situation.

Using CO<sub>2</sub> under ideal conditions\*: 35ms

Best reliability on CO<sub>2</sub>\*: 52ms

Using HPA with standard valving: 27ms

With QEV upgrade and HPA: 17ms

\* When using a CO<sub>2</sub> tank properly configured to prevent feeding liquid to the marker in warmer weather (see gasses section of this manual), the lower CO<sub>2</sub> dwell rate can be used. In colder weather, or if the marker begins showing signs of drop-off or mis-fires, the dwell must be increased for reliable operation.

# ELECTRONIC ADJUSTMENT

13.2 bps. The default BPS Fine Adjust setting is 0.

**Burst Count:** (Power Button LED blinks fast yellow) - This selects the number of shots fire per trigger pull when the maker is in burst mode. The burst number may be set to values between 2 and 4 shots. The default Burst Count value is 3 shots.

**FSDO Compensation:** (Power Button LED blinks slowly red) - When a marker rests, its bolt may stick in position and cause a low-velocity shot the next time it is fired. This is known as First Shot Drop-Off, or FSDO. FSDO Compensation increases the dwell time of the first shot of a group, providing additional time to break friction between the breech and the bolt's o-rings before the bolt moves forward. FSDO Compensation may be adjusted from zero (off) to 15 milliseconds in 1 millisecond increments. When the marker rests for 20 seconds or more, the next shot fired will have the FSDO Compensation value added to its dwell time. The default FSDO setting is 20 milliseconds.

**Vision™ Hardware:** (Power Button LED blinks slowly green) - This setting provides compatibility between the eXTCy™ circuit board and other markers. By default this setting will be 1, for use with the eXTCy™'s wired Vision™ eyes. A setting of 2 would be used for compatibility with circuit board style Vision™ eyes, such as those used for upgrade on the G-1™ and eNVy™.



# TRIGGER ADJUSTMENT

The length of the eXTCy™ trigger pull is fully adjustable.

A setscrew in the lower half of the trigger sets the post-travel adjustment, or how far back the trigger can be pulled. Turning the screw clockwise with a 0.05-inch allen wrench will shorten the trigger pull. Turning counter-clockwise will increase it. When setting post-travel limit, it is important that the trigger pull is not set so short that the trigger does not activate the microswitch on the eXTCy™'s circuit board, as this would leave the marker unable to fire. Similarly, the post-travel adjustment screw must butt up against the trigger frame when the trigger is pulled. If the post-travel screw is under-adjusted the trigger will stop against the microswitch inside the marker, instead of on the screw. This situation can cause damage to the microswitch and or circuit board when the trigger is pulled hard.

The forward limit of the trigger's movement, or pre-travel is adjusted by the use of a 1/8-inch allen wrench. The pre-travel trigger adjustment screw is located at the bottom of the trigger guard where it meets the grip frame. It may be helpful to remove the marker's rubber grips to provide easier access when making adjustments. As when changing the battery, it is better to completely remove the rubber grip than to only open one side and fold it past the trigger guard. Turning the pre-travel adjustment screw clockwise decreases how far forward the trigger can move, while turning counterclockwise increases. If the trigger is not adjusted to swing far enough forward when released, the microswitch inside the eXTCy™ will not be able to reset, resulting in the marker not firing.

Always check the trigger after making adjustments. Be sure that the trigger switch clicks when the trigger is pulled, and again when it is released. Also make sure that when the trigger is pulled it is being stopped by the post-travel adjustment screw, not by pressing up against the microswitch inside the marker.

## IMPORTANT

THE TRIGGER MUST COME TO A STOP WITH ITS ADJUSTMENT SCREW AGAINST THE GRIP FRAME OR DAMAGE TO THE CIRCUIT BOARD AND OR TRIGGER SWITCH MAY OCCUR.

FIG. 9 → TRIGGER ADJUSTMENT POINTS

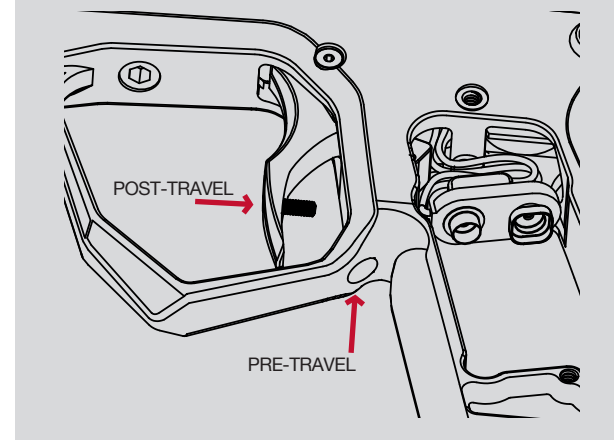

# UNLOADING/DE-GASSING

At the end of each day's use and before performing maintenance work on your eXTCy™, it will need to be de-gassed, and all paintballs must be removed.

In an area where it is safe to shoot (such as the chronograph area at a paintball field) and while wearing paintball goggles, remove the hopper from the eXTCy™. By turning the eXTCy™ upside down, you can empty any extra paintballs from the feedneck into your hand. Turn the eXTCy™ on.

Dry-fire 2 or 3 shots in a safe direction to ensure that no paintballs remain in the eXTCy™. In order to dry-fire the marker, the Vision™ anti-chop system must be turned off (see Vision™ operation) or set to one of its delayed modes (see Electronic Adjustment).

Turn off the HPA system if it is equipped with its own on/off control, or turn off the HPA system or CO<sub>2</sub> tank by turning the bottom-line ASA control knob counter-clockwise. Dry fire the eXTCy™ in a safe direction until all of the gas pressure inside has been released. At this point the only sound you should hear when you pull the trigger is the click of the solenoid valve. Often this sound will be too quiet to hear. Turn off the eXTCy™.

If using a CO<sub>2</sub> tank or screw in HPA system, unscrew it from the bottom-line ASA.

PLEASE READ CAREFULLY

## //////////⚠WARNING

EVEN WITH NO CO<sub>2</sub> OR COMPRESSED AIR SYSTEM ATTACHED, THE EXTCY™ MAY STILL HAVE ENOUGH GAS PRESSURE STORED IN THE REGULATOR AND FIRE CHAMBER TO FIRE 2 OR MORE SHOTS. YOU MUST DE-GAS YOUR EXTCY™ BEFORE PERFORMING ANY MAINTENANCE PROCEDURES.

## //////////⚠WARNING

ALWAYS WATCH COMPRESSED GAS CYLINDERS (CO<sub>2</sub> OR HPA) TO MAKE SURE THAT THE CYLINDER AND VALVE ARE UNSCREWING FROM THE ASA, AND THAT THE CYLINDER IS NOT UNSCREWING FROM ITS VALVE. IF THE CYLINDER DOES BEGIN TO SEPARATE FROM ITS VALVE, STOP IMMEDIATELY, AND SEEK PROFESSIONAL ASSISTANCE.

# FIELD STRIPPING

## CLEANING

The valve system in the eXTCy™ has only one major moving part. Regular cleaning and lubrication is necessary to ensure accurate and consistent performance. The eXTCy™ should be field stripped, cleaned and lubricated any time it shows erratic performance, becomes contaminated with paint, dirt or other debris, or for general maintenance after 3 or 4 days of use.

Unload and de-gas the eXTCy™. Remove the barrel and use a 5/16-inch allen wrench to unscrew and remove the bolt sleeve from the back.

Using a soft, non-marring tool like a wooden chopstick or plastic toothbrush, push the bolt and bolt stop out the back of the eXTCy™. Clean the interior of the receiver, the bolt sleeve, bolt and bolt stop with a clean cloth or paper towel. Inspect their o-rings for signs of damage such as cuts or rips, and replace if necessary. Lightly lubricate all o-rings with GR33SE™ paintgun grease. Use GR33SE™ sparingly, as over-lubrication can cause the eXTCy™ to operate inconsistently. Do not lubricate the rearmost o-ring on the bolt sleeve, it provides friction to keep the bolt sleeve in place during operation.

Slide the bolt stop onto the bolt from the rear. Slide the rear of the bolt into the bolt sleeve. Hold this entire assembly vertically with the front of the bolt pointing upward, and insert it up into the back of the eXTCy™. Screw the bolt sleeve into the back of the eXTCy™ by hand, taking care not to cross-thread it into the receiver.

Use the long end of a 5/16-inch allen wrench to turn the bolt sleeve until it is snug. Take care not to over-tighten the bolt sleeve, it only needs to fit snugly in place.

FIG. 10

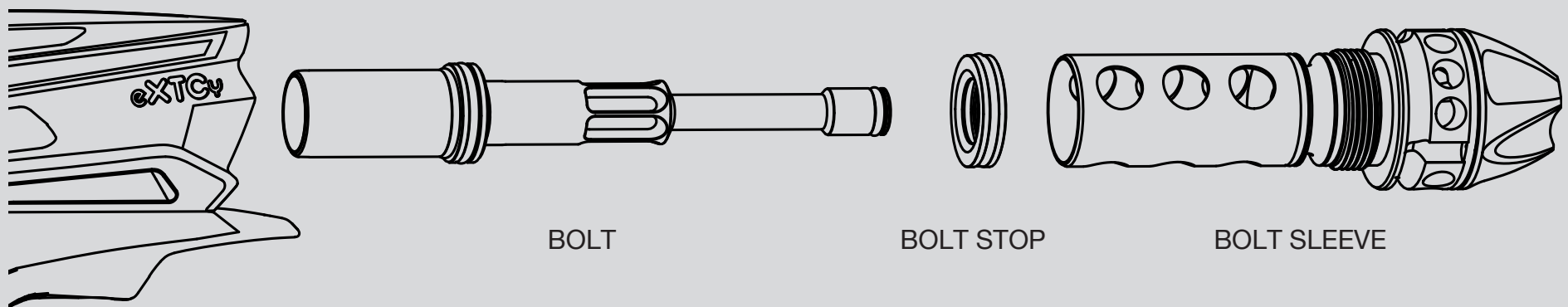

# VISION™/DETENT CLEANING

## CLEANING

The Vision™ eye covers of the eXTCy™ are easily removed to provide access to both the Vision™ sensors and the marker's ball-detents. To remove the eye covers, first unload and de-gas the marker following the instructions in this manual, then use a 0.050-inch allen wrench through the eye-cover access hole to unscrew the eye cover retaining screw, then tilt the eXTCy™ to the side, and if necessary tap it lightly against one hand to work the eye cover out.

With the eye cover removed, an o-ring pick can be used to pry the Vision™ LED or detector out of its pocket by one of its top corners. Care must be taken not to scratch the dome shaped lens molded into the body of the eye. With the eye gently folded out of the way, the eye, eye pocket and ball detent opening in the breech may all be thoroughly cleaned with a cotton swab.

If the ball detent is worn to the point that it does not protrude slightly into the breech, or dirty to the point that it does not spring easily in or out, it may be removed from the eye cover for cleaning or replacement. To remove the ball detent, use an o-ring pick to carefully pry back the ball detent retaining fingers one at a time and work the detent out of the eye cover. If the ball detent is excessively worn, it must be replaced for proper operation of the eXTCy™. The ball detent spring may become bent or damaged during removal of the ball detent. If this happens, it must be replaced. After cleaning or replacement, fit the ball detent spring into the ball detent, set its other end on the spring guide in the eye cover, then carefully work the detent past the detent retaining fingers. Note the alignment of the ball detent for a proper fit, its wider flat edges should be at the top and bottom.

When re-installing the eye cover, use the long end of the allen wrench to tighten the eye cover retaining screw. **Take care not to cross-thread the eye cover retaining screw, or tighten it beyond a snug fit, these can cause permanent, non-repairable damage to the breech.**

FIG. 11 → EYE COVER REMOVAL

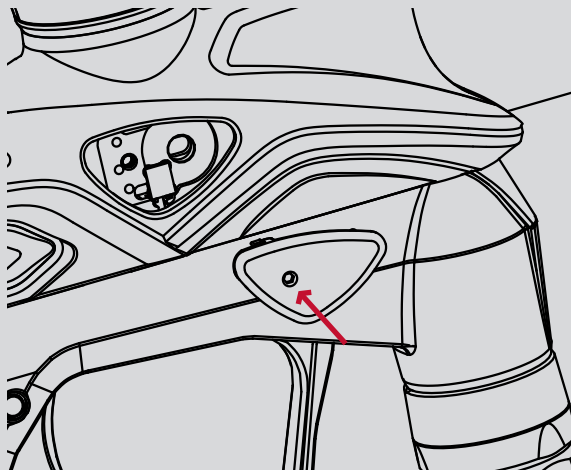

FIG. 12 → EYE CLEANING

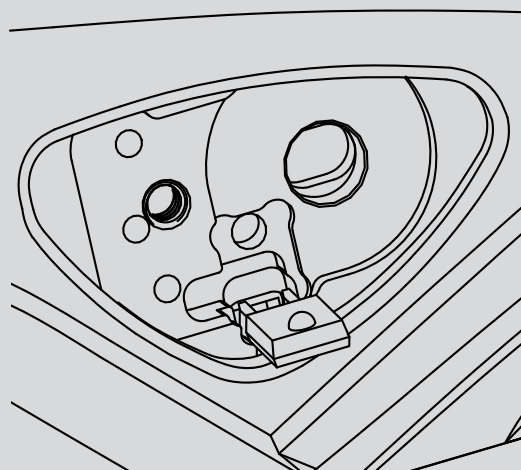
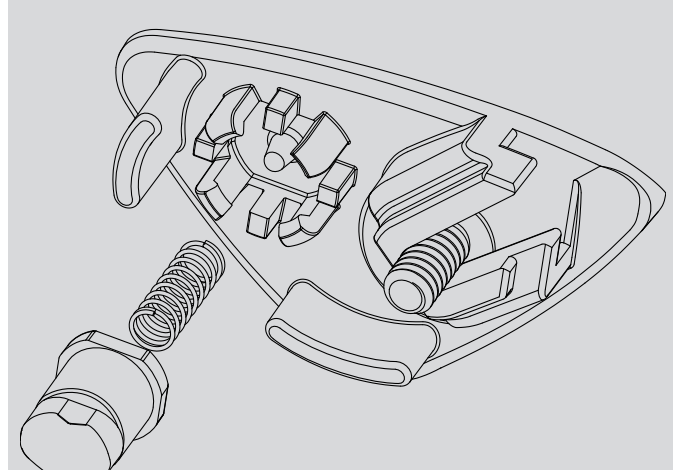

FIG. 13 → BALL DETENT REMOVAL



# ADVANCED MAINTENANCE

**NOTE:** Unload and degas the eXTCy™ before any cleaning or maintenance work.

The internal gas lines and electronic components of the eXTCy™ are well protected inside its body – however they are delicate and may be damaged by improper handling or re-installation. For this reason it is highly recommended that full disassembly of the eXTCy™ be performed by an airsmith with GOG Paintball™ factory training, and then only when necessary to fix a problem or install an upgrade. Removal of internal hoses from their barbed fittings will stretch them to the point that they cannot be re-used without causing leaks. In other words, if it ain't broke, don't fix it.

Occasionally a more thorough disassembly of the eXTCy™ receiver is necessary to remove paint or debris that has worked between the breech and body shell, replace a damaged component or install an upgrade. These tasks require removal of the grip frame and or disassembly of the body.

Unload and degas the eXTCy™, remove the barrel, rubber grip and battery, following the instructions in this manual. Similarly, field strip the bolt/valve system.

Using a 1/8-inch allen wrench, remove the breech screw from the front of the breech. Next remove the two grip frame screws securing the grip frame to the body. Carefully slightly separate the grip frame from the receiver. Be aware that the clear power button can fall out of its position in the side of the grip frame. Be careful not to drop or lose it. The body will still be connected to the grip frame by the hose running between the front of the grip frame and the solenoid valve on the circuit board.

Tilt the body slightly away from the grip frame and carefully use a 1/8-inch allen wrench to unscrew the barbed banjo fitting which connects the gas supply hose to the grip frame. Alternatively, the hose may be pulled off of the barb in the grip frame - doing so will require the hose to be replaced however, as its end will have been stretched by the barbed fitting and will no longer seal reliably.

Completely separate the body from the grip frame. Watch to make sure the battery clip does not snag in the grip frame as the two parts are separated.

Reassembly of the grip frame to the body is done in the reverse order, taking care not to allow the battery wires to or hoses to become pinched or entrapped while joining the body to the grip frame. Use the long end of the allen wrench when reinstalling the banjo fittings and grip frame screws, to avoid over-tightneing.

## //////////⚠WARNING

Over-tightening or cross threading screws or fittings may result in permanent, nonrepairable damage to the breech.

FIG. 14 → BREECH SCREW REMOVAL

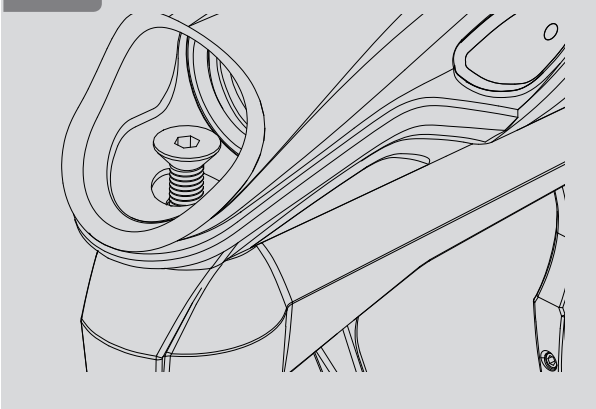
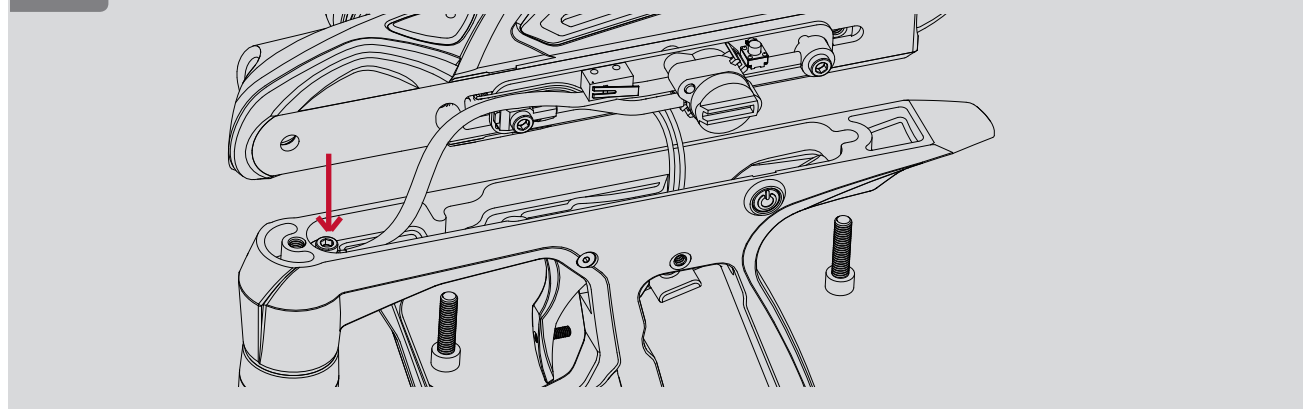

FIG. 15 → GRIP FRAME REMOVAL



# ADVANCED MAINTENANCE

CONTINUED

The circuit board is removed from the body by first unplugging the Vision™ wiring harness from its socket. Take care to grasp the plug and remove it - do not pull by the wires or they may be damaged.

Using a 1/8-inch allen wrench, unscrew the 2 banjo fittings which attach the circuit board to the body and breech.

The circuit board may then be carefully lifted away from the body and breech.

When re-attaching the circuit board to the body and breech, take extreme care not to cross thread the fittings. Use the long end of the allen wrench to tighten the gas fittings and all screws, being careful to tighten them snug without over tightening. **Over-tightening or cross threading screws or fittings may result in permanent, nonrepairable damage to the breech.**

Be sure to guide the battery clip down into the grip frame before re-joining the grip frame and receiver. Make sure the clear power button does not fall out of its place during reassembly.

Be certain all wires and hoses are tucked into their places before rejoining the grip frame to the receiver. If the grip frame does not fit snugly to the receiver do not force it. Instead, pull the grip frame back away and look for hoses, wire, or improperly placed parts blocking the fit.

FIG. 16 → UNPLUG VISION™ WIRING

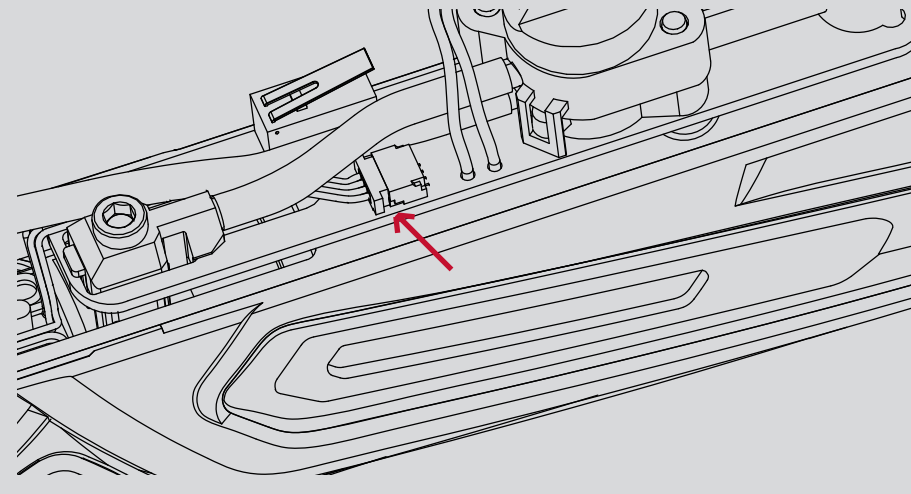
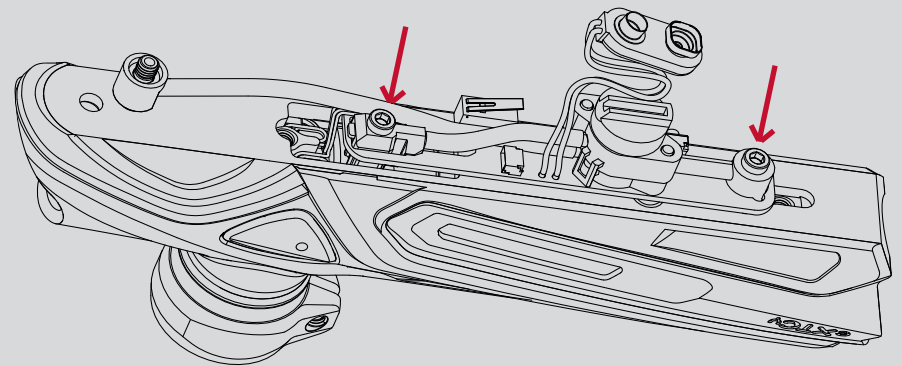

FIG. 17 → UNSCREW BANJO FITTINGS





# ADVANCED MAINTENANCE

CONTINUED

If removing the breech from the body cover, the Vision™ wiring harness must be removed first. Uncoil the Vision™ wires and remove both eyes from their pockets (see Vision™/detent cleaning). Carefully twist each eye so that its dome shaped lens faces forward and guide it down through the slot in the breech and out the bottom of the body shell, gently pulling its wires ahead of it so they do not bind.

Slide the breech out the back of the body cover. Carefully clean any paint or debris from the breech and body cover. The circuit board may then be carefully lifted away from the body and breech.

After sliding the breech back into place, the Vision™ wiring harness and eyes are reinstalled via the same openings through which they were removed. Coil the Vision™ wires into their pocket as shown before reinstalling the circuit board.

FIG. 18 → ROTATE AND REMOVE EYES

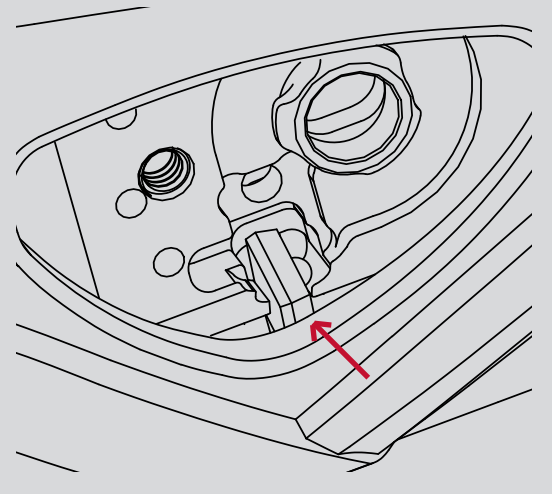

FIG. 19 → SLIDE BREECH OUT BACK

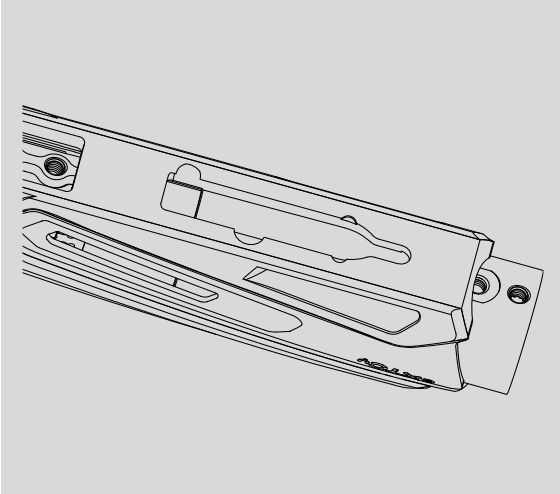
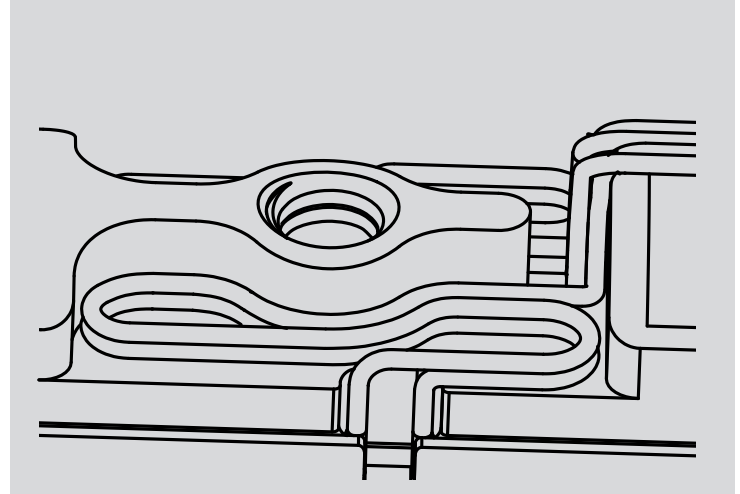

FIG. 20 → COILED VISION™ WIRES



# VERTICAL REGULATOR

## REGULATOR SERVICE

Although explained here, regulator service should only be performed by a GOG Paintball™ trained airmith.

With the marker unloaded and de-gassed, unscrew the regulator from the marker and remove the grip frame following the instructions in this manual. Take care not to lose the filter screen that sits inside the vertical regulator's ASA connection.

Using a pair of snap-ring pliers, remove the snap-ring from the bottom of the regulator and slide the regulator off the swivel. This is the preferred way to separate the regulator from the hose and bottomline ASA because it does not disturb the sealed hose fittings and is not likely to cause a leak.

Using a 7/16 open end or adjustable wrench, engage the wrench flats in the sides of the spring platform and remove it from the bottom of the regulator body. The regulator spring will now be free to fall out into your hand. The brass regulator piston may be removed by tapping the regulator body against a table top or solid, but soft surface such as a block of wood.

At this level of disassembly, the seal in the end of the piston and the regulator body may be inspected, cleaned with a soft cloth or cotton swab, and replaced if necessary. If the regulator seal shows signs of damage, it may be removed and flipped over so that its back side is used instead. If both sides of the seal are damaged, it must be replaced. Lightly lubricate all o-rings with GR33SE™ for reassembly.

Do not lubricate the regulator seal at the end of the piston.

## WARNING

SERVICE AND ADJUSTMENT TO THE REGULATOR WILL CAUSE CHANGES IN VELOCITY. ALWAYS RE-CHRONOGRAPH THE MARKER FOLLOWING THE PROCEDURE IN THIS MANUAL AFTER WORKING WITH THE REGULATOR.

FIG. 21 REGULATOR DISASSEMBLY

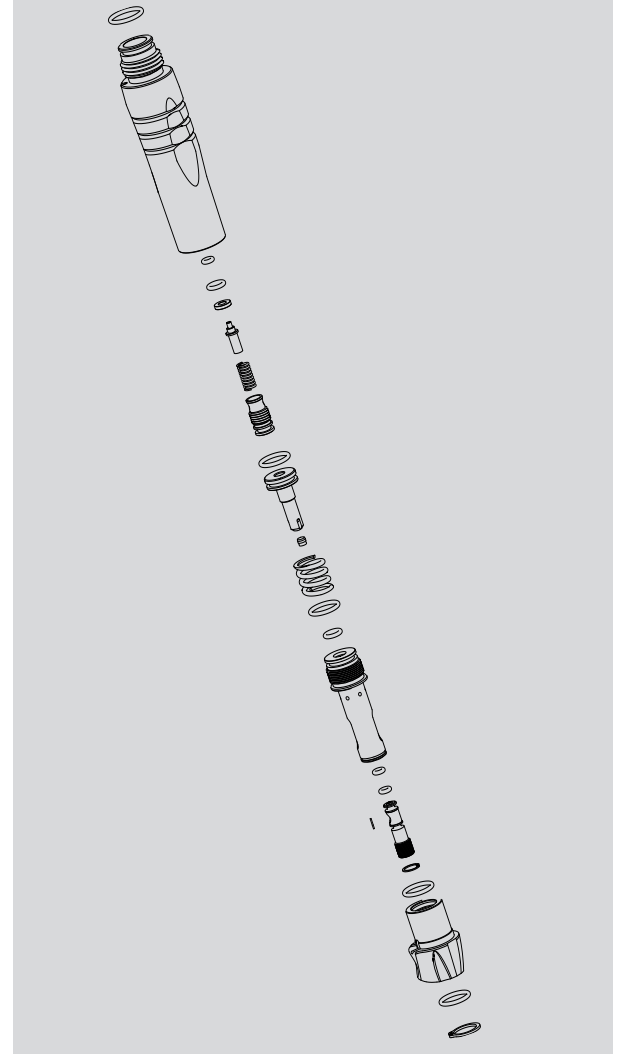

# VERTICAL REGULATOR

[ CONTINUED ]

## REGULATOR SERVICE, CONTINUED

The relief valve assembly should only be removed if it is constantly leaking. Occasional venting, especially if using CO<sub>2</sub>, is normal and does not indicate a malfunction. The relief valve assembly may be removed with a 5/32-inch allen wrench.

The velocity adjuster is located inside the lower end of the spring platform and similarly should only be removed if shown to be the source of a leak or clog. First the internal c-clip ring must be removed from inside the spring platform. This must be done with a pair of narrow snap-ring pliers. Some airsmiths have used bench grinders to re-shape standard snap-ring pliers for this task. The adjuster is equipped with left-hand threads and will need to be turned clockwise for removal. If regulator blockage is suspected, be sure to inspect, and if necessary replace the inlet filter in the side of the velocity adjuster.

The vertical regulator is reassembled in the reverse order of disassembly. The piston slides into the regulator body wide end first, followed by the regulator spring. The spring platform should be tightened for a snug fit. Do not over-tighten. Re-attach the regulator swivel to the bottom end of the regulator and secure it in place with its snap-ring. Reinstall the assembled regulator into the marker. Re-adjust velocity after servicing the regulator.

## //////////▲NOTICE

THE RELIEF VALVE IN THE VERTICAL REGULATOR PROVIDES PROTECTION AGAINST PRESSURE SPIKES CAUSED BY SEAL FAILURE OR LIQUID CO<sub>2</sub>. REPLACING THE VERTICAL REGULATOR WITH ANY OTHER BRAND OR MODEL WILL BY-PASS AN IMPORTANT SAFETY FEATURE CREATING A RISK OF EQUIPMENT FAILURE OR INJURY AND INVALIDATING THE GOG PAINTBALL™ WARRANTY.

# TROUBLESHOOTING

IMPORTANT

## MARKER IS LEAKING INTERNALLY

- Liquid CO<sub>2</sub> may cause temporary venting from relief valve or solenoid valve. This is normal, and does not require repair. If CO<sub>2</sub> is venting frequently, make sure the marker is properly configured to prevent feeding of liquid CO<sub>2</sub>.
- Pneumatic hoses may be loose, damaged or not fully connected. Replace hoses with genuine GOG Paintball™ hoses only.
- Hose has been disconnected and re-attached. Replace with a new GOG Paintball™ internal hose. Removing a hose stretches it so that it cannot be re-used without leaking.

## MARKER IS LEAKING DOWN THE BARREL

- One or more of the bolt or bolt stop o-rings are damaged or dirty. Inspect and replace if necessary, making sure to clean and lubricate the parts following the instructions in this manual.

## MARKER IS LEAKING FROM BOTTOMLINE ASA

- Unload and de-gas the marker. Inspect the CO<sub>2</sub> or HPA tank o-ring. Clean, lightly lubricate with GR33SE™ and if necessary replace.

## MARKER IS OCCASIONALLY LEAKING FROM THE VERTICAL REGULATOR

- Gas may occasionally vent near the top of the vertical regulator (see Fig. 21) especially when using CO<sub>2</sub>. This is a normal function of the relief valve protecting the marker, and does not indicate a problem. If CO<sub>2</sub> is venting frequently, make sure the marker is properly configured to prevent feeding of liquid CO<sub>2</sub>.

FIG. 21 RELIEF VENT

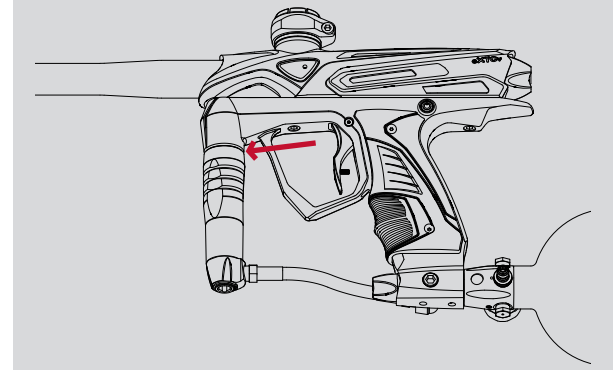

# TROUBLESHOOTING

IMPORTANT

## MARKER EXHIBITS FIRST SHOT DROP-OFF (FSDO)

- FSDO is a low velocity, or non-firing first shot, followed by normal shooting and is often caused by debris in the bolt or a poorly lubricated bolt. Clean the bolt, breech, bolt stop and bolt sleeve, and lubricate them with GR33SE™ as instructed in the Field Stripping section of this manual.
- FSDO can be caused by dwell and or FSDO Compensation settings that are too low for the marker's gas supply and configuration. Follow the directions in the Electronic Adjustment section of this manual and set the dwell to the minimum recommended setting for the marker's gas supply and configuration or higher, and the FSDO Compensation setting to the default value or higher.

## MARKER EXHIBITS INCONSISTENT VELOCITY

- Check paint quality. Your marker is optimized for use with fresh, high-quality paintballs. Paintballs of inconsistent quality, or paintballs that have been exposed to humidity or temperature extremes may vary in size or roundness causing inconsistent operation.
- Gas pressure could be low. Fill gas source and make sure gas supply is turned on.
- Battery may be low. This will be most noticeable with velocity dropping and then entire shots not firing during rapid fire. Replace battery with a new name brand alkaline battery.
- Regulator may be contaminated or damaged. Follow the instructions in this manual or see a GOG Paintball™ technician for service.
- Liquid CO<sub>2</sub> may be entering the regulator – if using CO<sub>2</sub>, see the gasses section of this manual for guidance in proper CO<sub>2</sub> set-up.
- Dwell value may be too low. Increase Dwell setting and retest.

# TROUBLESHOOTING

## MARKER WILL TURN ON BUT WILL NOT FIRE

- Battery may be low or dead – replace with fresh name brand alkaline battery.
- The forward trigger limit adjustment screw may be set in too far, preventing the trigger from resetting. See the trigger adjustment section of this manual for guidance.
- The rear trigger limit adjustment screw may be set in too far, stopping the trigger before it can fire the marker. See the trigger adjustment section of this manual for guidance.
- Trigger switch may be damaged. Contact your dealer or GOG Paintball™ technical support.
- Regulator output pressure may be too high. Adjust the velocity to its lowest limit, then follow the velocity adjustment procedure in this manual.
- Liquid CO<sub>2</sub> may be entering the valve – see the gasses section of this manual for guidance in proper CO<sub>2</sub> set-up.

## MARKER IS BREAKING PAINT OR DOUBLE-FEEDING

- Use only fresh, high-quality paintballs. Poor quality paint, or paint damaged by humidity or temperature extremes during shipping or storage, will not perform well.
- Ball detents may be worn, dirty or damaged. Inspect, and if necessary, replace following the instructions in this manual.
- The Vision™ anti-chop function may be turned off. Turn Vision™ on, following the instructions in this manual.

## VELOCITY DROPS-OFF DURING RAPID FIRE

- Use fresh alkaline 9v battery.
- If using CO<sub>2</sub>, especially in colder weather, reduced rates of fire may be necessary.
- Dwell may be too high, reducing time available for recharge - decrease Dwell value.

## IMPORTANT

### TECH SUPPORT

Our Technical Support Department can provide assistance via telephone. See our web site for phone number and tech support hours. Additional support and downloadable product manuals are available through our website at [GOGPaintball.com](http://GOGPaintball.com)

### WARRANTY

GOG Paintball SA warrants for (1) year to initial retail purchaser that the paintball marker and regulator are free from defects in materials and workmanship. Disposable parts (batteries, o-rings, springs, seals, etc.) are not warranted. The valve assembly, solenoid and electronics are warranted for 6 months. This warranty does not cover surface damages (scratches and nicks), misuse, improper disassembly and re-assembly, attempts made to drill holes or remove metal from the external surfaces which could degrade performance and reduce pressure safety factors of the marker. Do not make changes to the basic marker parts without written approval. The only authorized lubricant for the marker is DOW 33 lubricant. Use of any other lubricant could result in voiding your warranty. Paintball markers are non-refundable. This warranty is limited to the repair or replacement of defective parts with the customer to pay shipping costs. This warranty is effective only if the customer registers the product online @ [gogpaintball.com](http://gogpaintball.com) within 30 days of the purchasing the marker. The warranty is non-transferrable. Do not attempt to alter the trigger assembly in any way, as this will void your GOG warranty. Trigger alteration of any kind may result in serious injury.



# PARTS DIAGRAMS

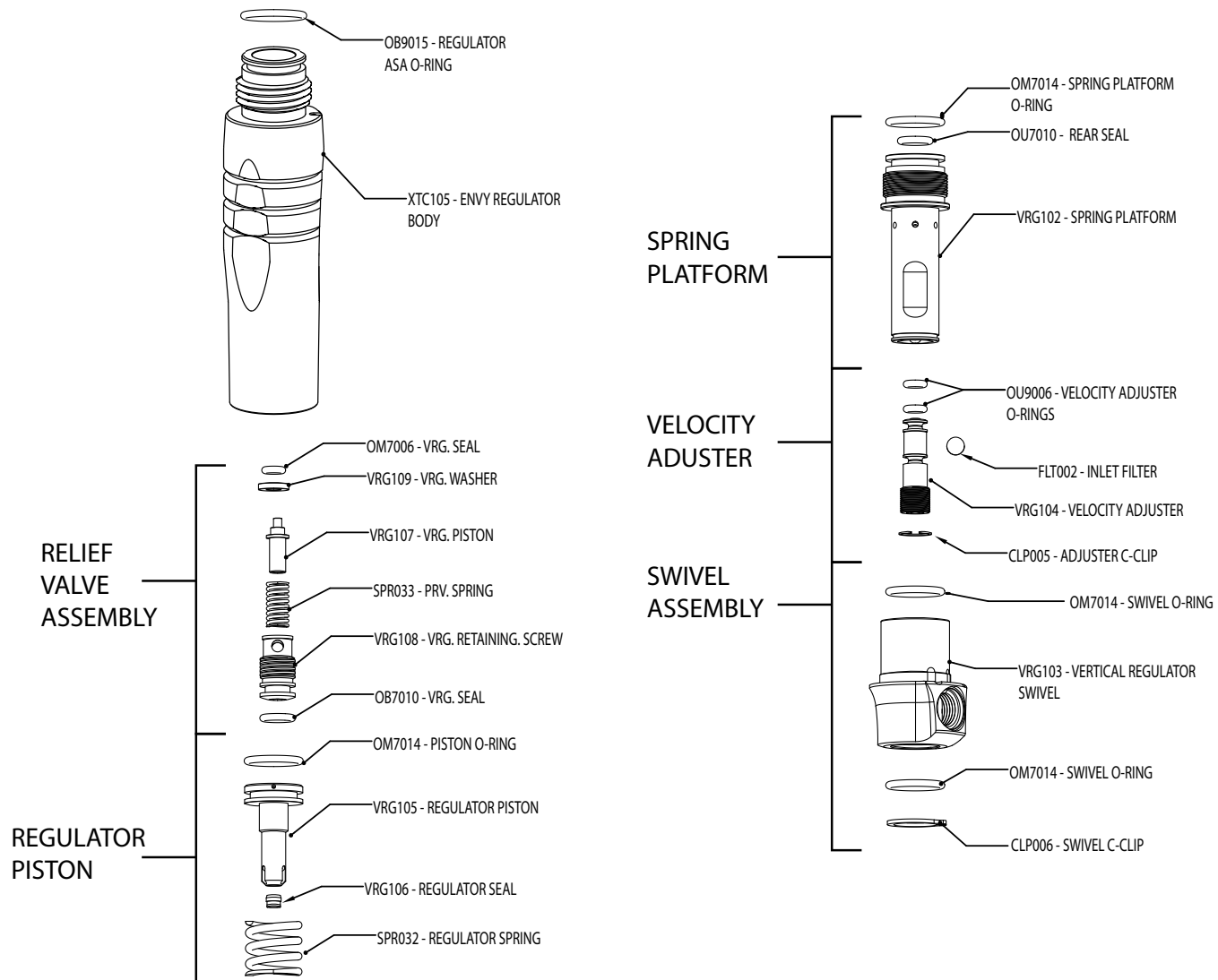

# PARTS DIAGRAMS

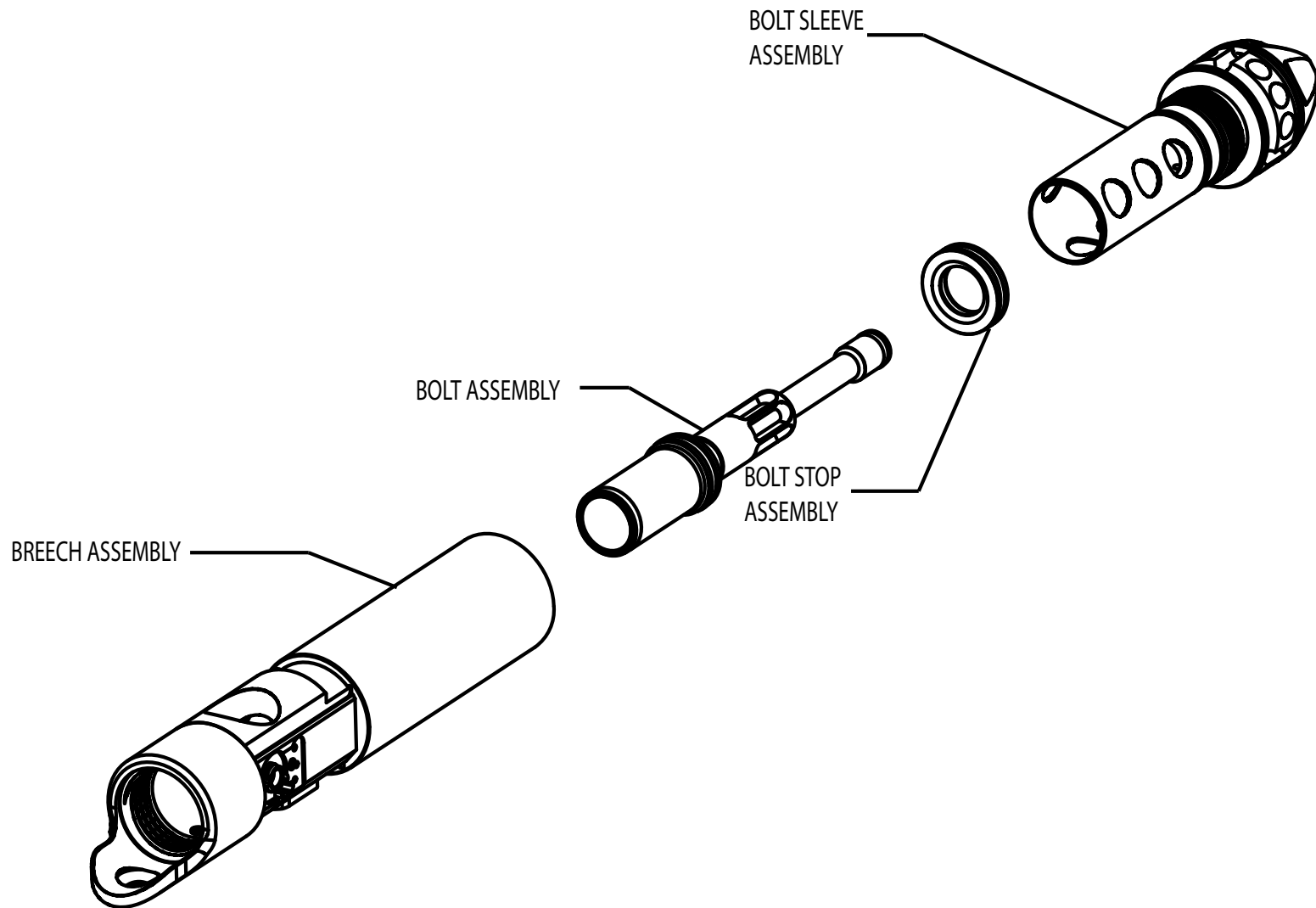

# PARTS DIAGRAMS

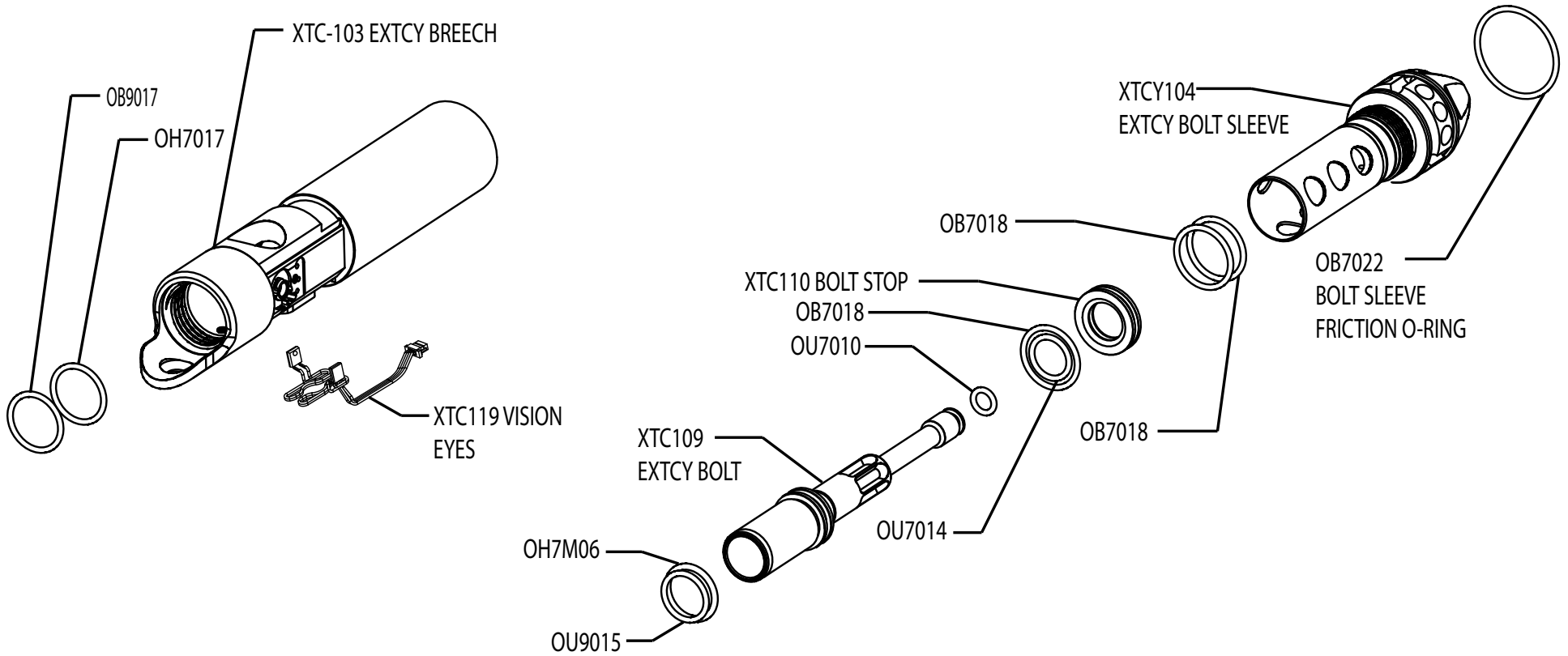

# PARTS DIAGRAMS

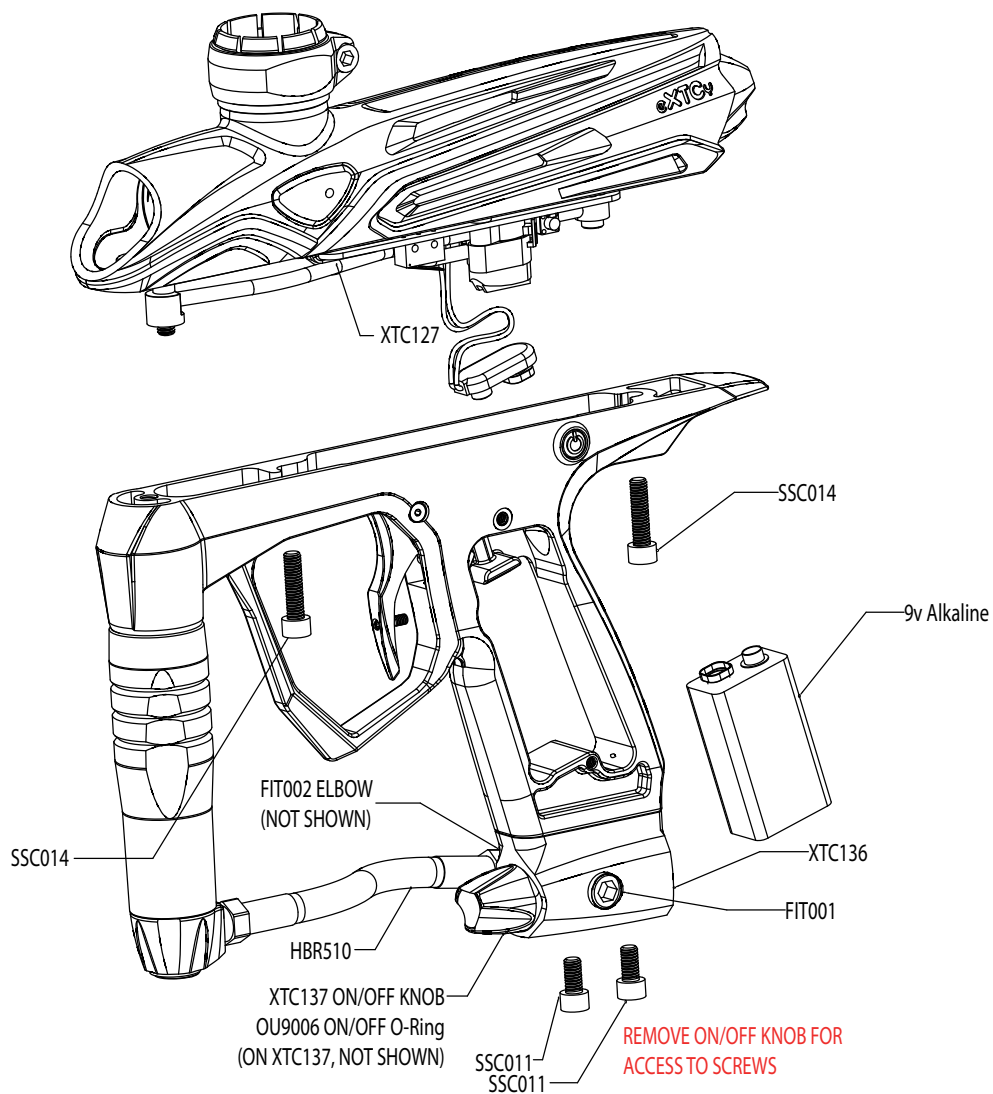

# PARTS DIAGRAMS

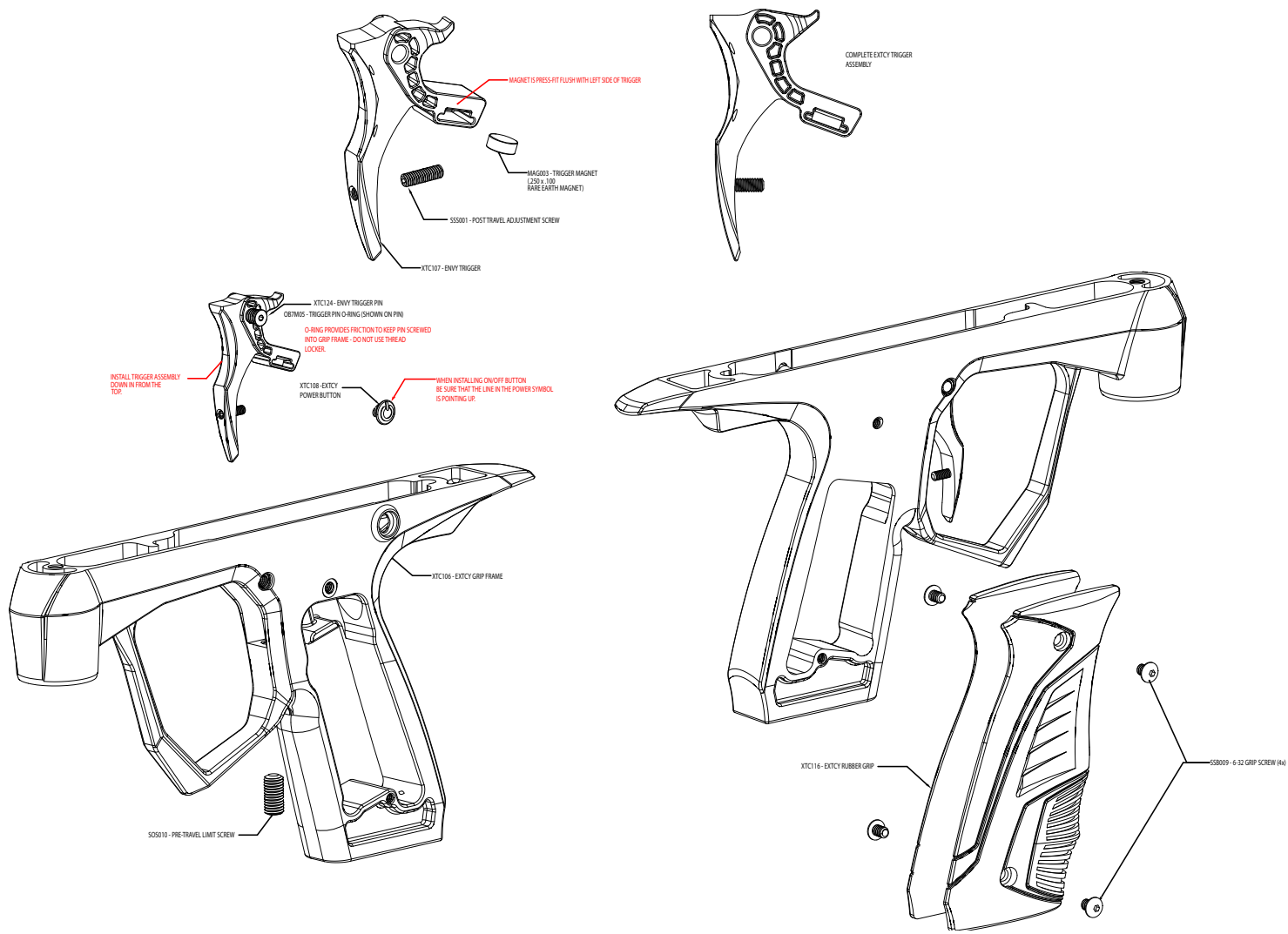

# PARTS DIAGRAMS

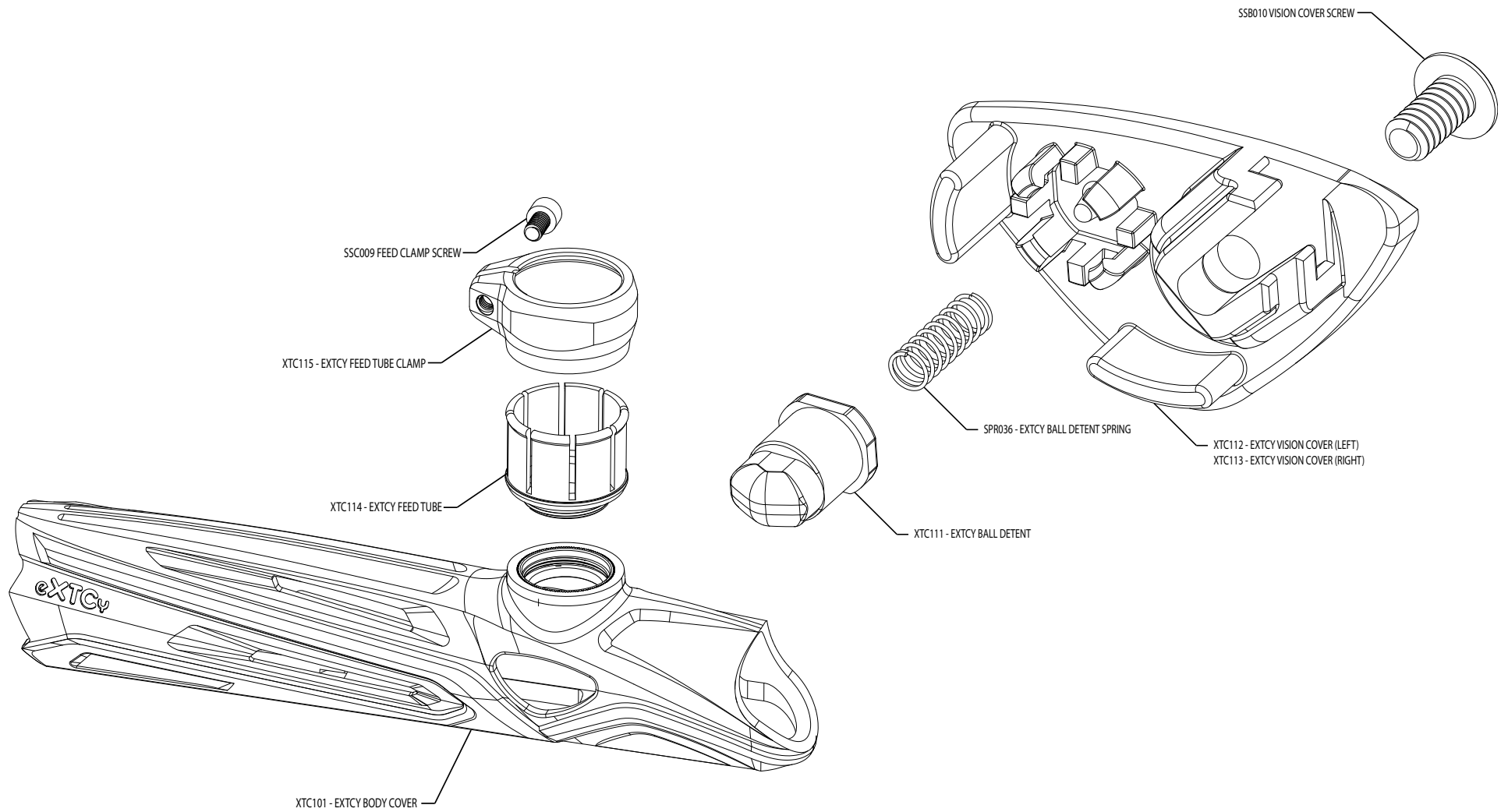



eXTCy™ Manual V1.21 © Copyright 2011, GOG Paintball, SA, all rights reserved.  
eXTCy, GR33SE, GOG, GOG Paintball and the GOG Paintball logos are trademarks or registered trademarks of GOG Paintball, SA.

[GOGpaintball.com](http://GOGpaintball.com)